

THE ARRL

TENTH
EDITION

GENERAL

LICENSE COURSE **FOR**
HAM

All You Need to Pass Your General Class Exam!

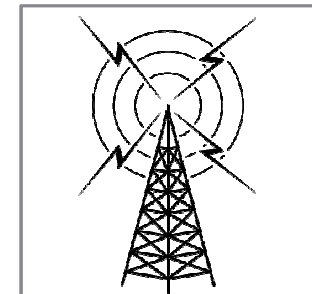
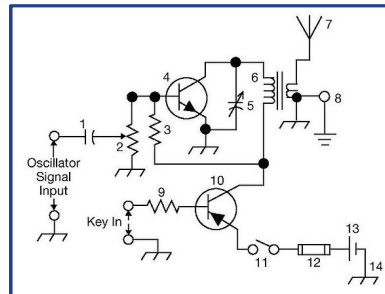

Resource & Reference

www.arrl.org/shop/Licensing-Education-and-Training

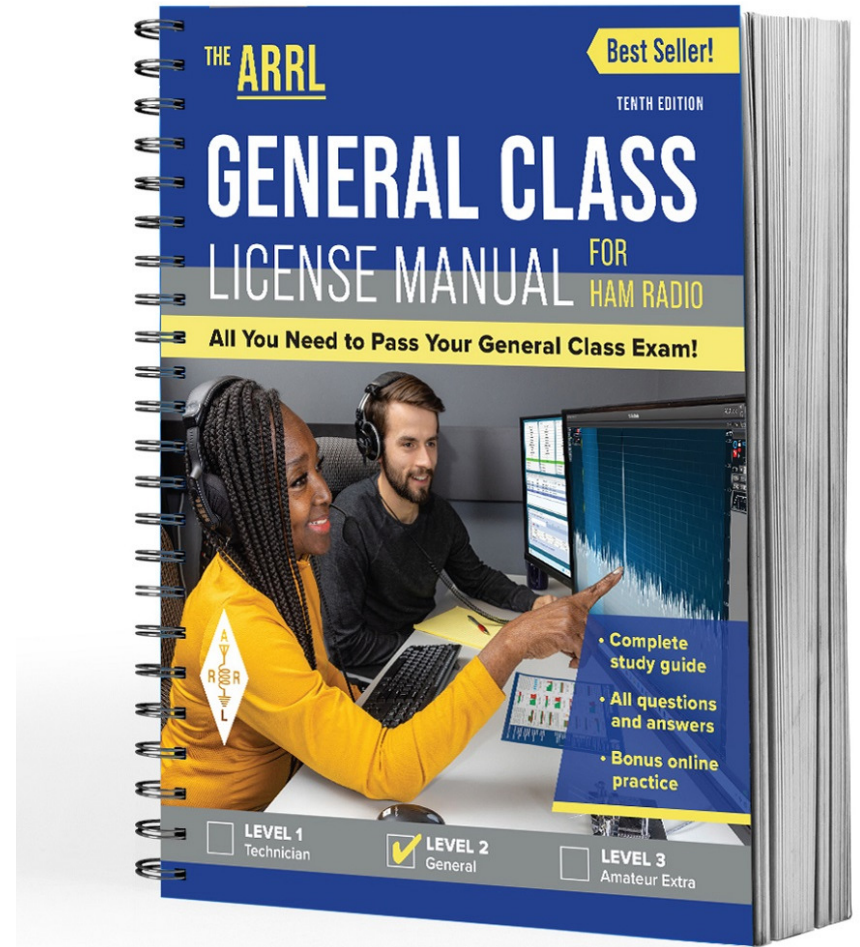

Chapter 4 Part 1 of 3

ARRL General Class
Components & Circuits
Sections 4.1, 4.2, 4.3

Power & Decibels, AC Power, Basic Components

Section 4.1

Power and Decibels

Recall Ohm's Law from your Technician training

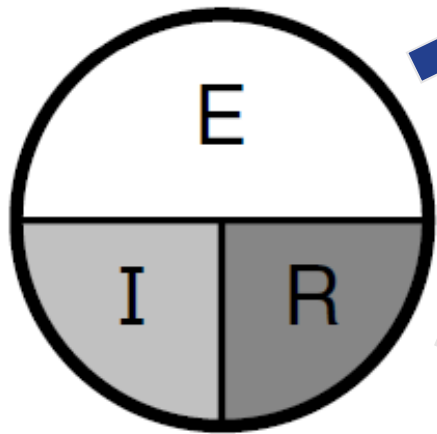

$$E = I \times R$$

$$I = \frac{E}{R}$$

$$R = \frac{E}{I}$$

E = Voltage
I = Current
R = Resistance

Power and Decibels (cont.)

Similarly ...

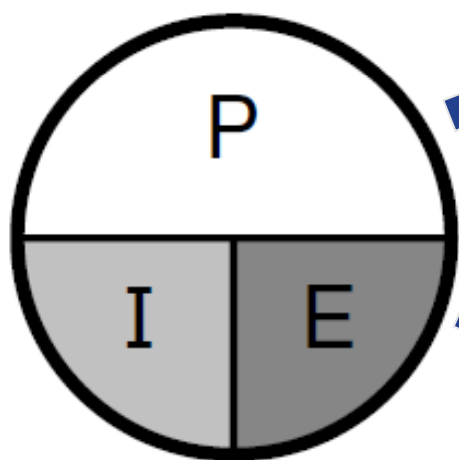

$$P = E \times I$$

$$E = \frac{P}{I}$$

$$I = \frac{P}{E}$$

E = Voltage

I = Current

P = Power

Power and Decibels (cont.)

Substituting the Ohm's Law equivalents for voltage and current allows power to be calculated using resistance ...

$$P = I^2 \times R$$

$$P = \frac{E^2}{R}$$

Power Calculation Examples

To find out how many watts of electrical power are used if 400 Vdc is supplied to an 800 Ω resistor ...

$$P = \frac{E^2}{R} = \frac{400^2}{800} = \frac{400 \times 400}{800} = \frac{160000}{800} = 200 \text{ W}$$

Power Calculation Examples (cont.)

To find out how many watts of electrical power are used by a 12 V dc light bulb that draws 0.2 A ...

$$P = E \times I = 12 \times 0.2 = 2.4 \text{ W}$$

Power Calculation Examples (cont.)

To find out how many watts are being dissipated when a current of 7.0 mA flows through a 1.25 k Ω resistor ...

$$\begin{aligned} P &= I^2 \times R = 0.007^2 \times 1250 = \\ &0.007 \times 0.007 \times 1250 = 0.06125 \text{ W} = \\ &61.25 \text{ mW} \end{aligned}$$

Remember: (a) 7 mA = 0.007 A, (b) 1.25 k Ω = 1250 Ω

Calculating a Power or Voltage Ratio from dB

$$\text{Power Ratio} = \log^{-1} \left[\frac{\text{dB}}{10} \right]$$

$$\text{Voltage Ratio} = \log^{-1} \left[\frac{\text{dB}}{20} \right]$$

Inverse log notes ...
(referred to as *antilog*)

Written as ... \log_{10}^{-1}
or ... \log^{-1}

On scientific calculators ...

LOG⁻¹

ALOG

10^X

INV then LOG

Example Power & Voltage Ratio Calculations

$$\text{Power ratio of 9 dB} = \log^{-1}(9/10) = \log^{-1}(0.9) = 8$$

$$\text{Voltage ratio of 32 dB} = \log^{-1}(32/20) = \log^{-1}(1.6) = 40$$

Useful Power vs. dB Value to Remember

If you double the power (or cut it in half), there's a 3 dB change ...

$$\text{dB} = 10 \log_{10} \left[\frac{2}{1} \right] = 10 \log_{10} (2) = 10 \times (0.3) = 3 \text{ dB}$$

Converting dB to Percentage & Vice Versa

$$dB = 10 \log \left(\frac{\text{Percentage Power}}{100\%} \right)$$

$$\text{Percentage Power} = 100\% \times \log^{-1} \left(\frac{dB}{10} \right)$$

$$dB = 20 \log \left(\frac{\text{Percentage Voltage}}{100\%} \right)$$

$$\text{Percentage Voltage} = 100\% \times \log^{-1} \left(\frac{dB}{20} \right)$$

Application example: Suppose you are using an antenna feed line that has a loss of 1dB. You can calculate the amount of transmitter power that's actually reaching your antenna and how much is lost in the feed line.

$$\text{Percentage Power} = 100\% \times \log^{-1} \left(\frac{-1}{10} \right) = 100\% \times \log^{-1}(-0.1) = 79.4\%$$

79.4% of your transmit power reaches the antenna ... 20.6% is lost in the feed line.

Current, Voltage, and Power Review

- **Current** (I) is the flow of electrons
 - Measured in *amperes* (A or amps) with an *ammeter*
- **Voltage** (E) is the force that makes electrons move
 - Measured in *volts* (V) with a *voltmeter*
 - Polarity of voltage refers to direction from positive to negative
- **Power** (P) is the product of voltage and current ($P = E \times I$)
 - Measured in *watts* (W)

Resistance and Ohm's Law Review

- Ohm's Law states ...

- $R = E / I$
- $I = E / R$
- $E = I \times R$

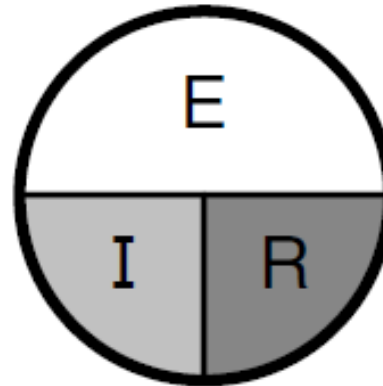

- The voltage caused by current flowing through a resistance is called a *voltage drop*

Frequency Review

- A complete sequence of ac current (alternating current) flowing, stopping, reversing, and stopping again is a *cycle*
- The number of cycles per second is the current's *frequency* (f), measured in *hertz* (Hz)
- A *harmonic* is a frequency at some integer multiple (2, 3, 4, etc.) of a lowest or *fundamental* frequency
 - The harmonic at twice the frequency is the *second harmonic*, at three times is the *third harmonic* (there is no first harmonic)

Wavelength Review

- Speed of light in space (**c**) is 300 million (3×10^8) meters per second ... somewhat slower in wires and cables
- Wavelength (**λ**) of radio wave is the distance it travels during one complete cycle
 - $\lambda = c / f$
 - $f = c / \lambda$
- A radio wave can be referred to by frequency **OR** wavelength because the speed of light is constant

Series and Parallel Circuits

- Circuit: Any complete path through which current can flow
- Series Circuit: Two or more components are connected so that the same *current* flows through all of the components
- Parallel Circuit: Two or more components are connected so that the same *voltage* is applied to all of the components

Decibels (dB)

- Formula: $\text{dB} = 10 \log_{10} (\text{power ratio}) = 20 \log_{10} (\text{voltage ratio})$
- Comparing a measured power or voltage to a reference value ...

$$\text{dB} = 10 \log_{10} \left(\frac{P_M}{P_{\text{REF}}} \right) = 20 \log_{10} \left(\frac{V_M}{V_{\text{REF}}} \right)$$

- Positive dB values mean the ratio is > 1 and are called *gain*
- Negative dB values (ratio < 1) are called *loss* or *attenuation*

PRACTICE QUESTIONS

What dB change represents a factor of two increase or decrease in power?

- A. Approximately 2 dB
- B. Approximately 3 dB
- C. Approximately 6 dB
- D. Approximately 9 dB

How many watts of electrical power are used if 400 VDC is supplied to an 800-ohm load?

- A. 0.5 watts
- B. 200 watts
- C. 400 watts
- D. 3200 watts

How many watts of electrical power are used by a 12 VDC light bulb that draws 0.2 amperes?

- A. 2.4 watts
- B. 24 watts
- C. 6 watts
- D. 60 watts

How many watts are consumed when a current of 7.0 milliamperes flows through a 1,250-ohm resistance?

- A. Approximately 61 milliwatts
- B. Approximately 61 watts
- C. Approximately 11 milliwatts
- D. Approximately 11 watts

What percentage of power loss is equivalent to a loss of 1 dB?

- A. 10.9 percent
- B. 12.2 percent
- C. 20.6 percent
- D. 25.9 percent

Section 4.2

AC Power / RMS: Definition & Measurement

- The power equation is very clear for dc power ... $P = E^2 / R$
- However, what is the value of E for ac power?
 - Not peak, not average ... it's *RMS* (*root mean square* or V_{RMS})
- If RMS voltage is used in the equations shown for calculating power (previous slides), the result for the ac signal is the same as for an unvarying dc voltage
- The RMS for a sine wave is 0.707 times the sine wave's peak voltage ... see Figure 4.2 (next slide)

Figure 4.2

Relationships between RMS, average, peak, and peak-to-peak ac voltage and current

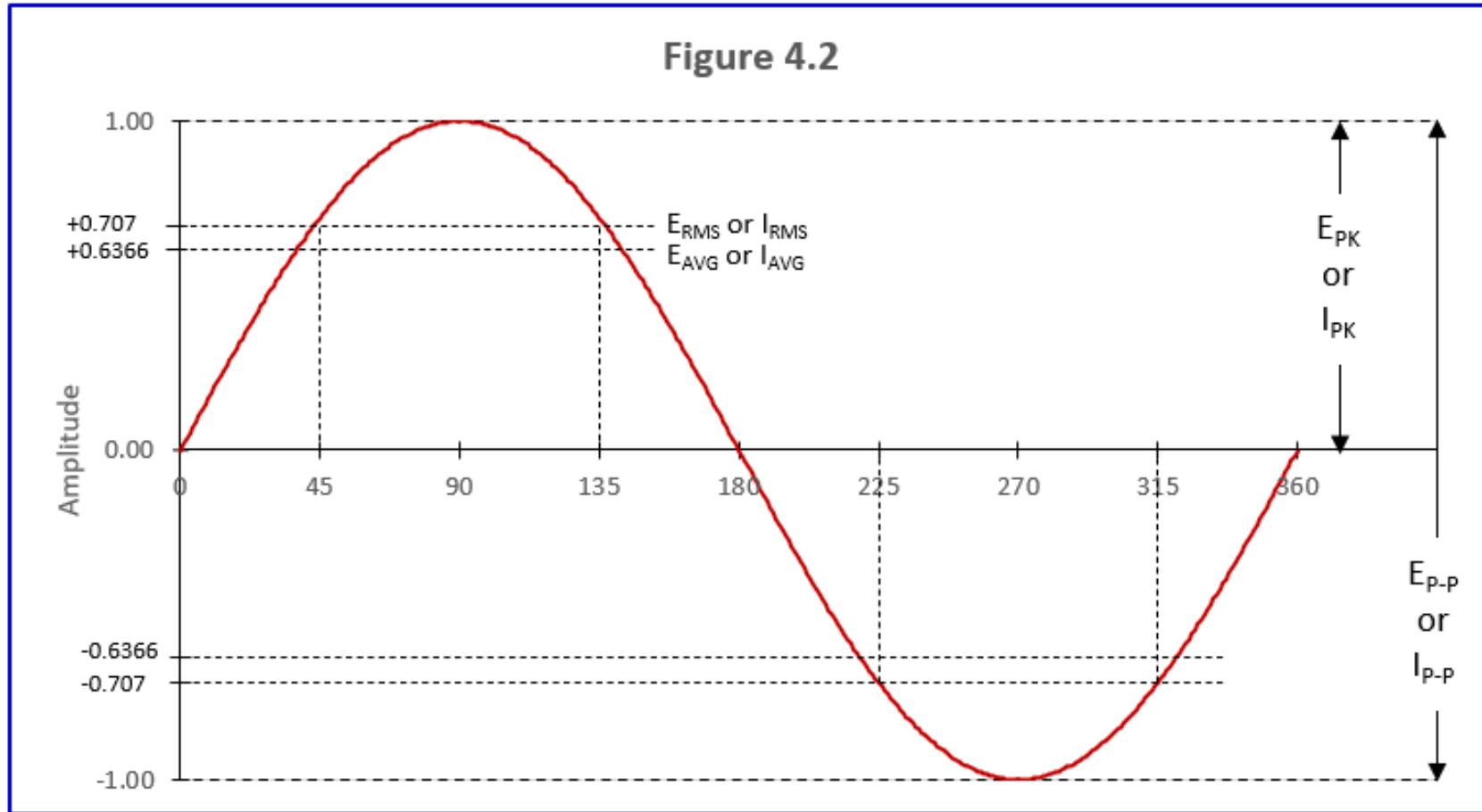

Waveform Formulas

(Note: Do not use these for non-sine waves!)

$$V_{RMS} = 0.707 \times V_{PK} = 0.707 \times \frac{V_{PP}}{2}$$

$$V_{PK} = 1.414 \times V_{RMS}$$

$$V_{PP} = 2 \times 1.414 \times V_{RMS} = 2.828 \times V_{RMS}$$

It is particularly important to know the relationship between RMS and peak voltages to choose components that have sufficient voltage ratings. Capacitors are often connected across the ac power line to perform RF filtering. The capacitor must be rated to withstand the ac peak voltage.

Refer to Figure 4.2

Waveform Calculation Examples

Example: A sine wave with a peak voltage of 17 V has what RMS value?

$$V_{\text{RMS}} = 0.707 \times V_{\text{PK}} = 0.707 \times 17 \text{ V} = \mathbf{12 \text{ V}}$$

Example: A sine wave with a peak-peak voltage of 100 V has what RMS value?

$$V_{\text{RMS}} = 0.707 \times \frac{V_{\text{P-P}}}{2} = 0.707 \times \frac{100}{2} = \mathbf{35.4 \text{ V}}$$

Example: A sine wave with an RMS voltage of 120.0 V has what peak-to-peak voltage value?

$$V_{\text{P-P}} = 2 \times 1.414 \times 120 = 2.828 \times 120 = \mathbf{339.4 \text{ V}}$$

PEP: Definition and Measurement

- PEP = *Peak envelope power*
- PEP is the *average power* of one complete RF cycle at the peak of the signal's envelope ... a convenient way of measuring the max power of amplitude-modulated signals
- However, this definition is confusing ...
 - See (following slide) definition from ARRL General Manual and www.mdarc.org

Clarification of Peak Envelope Power

PEP (or peak envelope power) is the average power of one complete RF cycle at the peak of the signal's envelope. PEP is used because it is a convenient way to measure or specify the maximum power of amplitude-modulated signals.

To calculate average ac power, you need to know the load impedance and the RMS voltage. Measure the RF voltage at the very peak of the modulated signal's envelope — this is the peak envelope voltage (PEV) as shown in this figure.

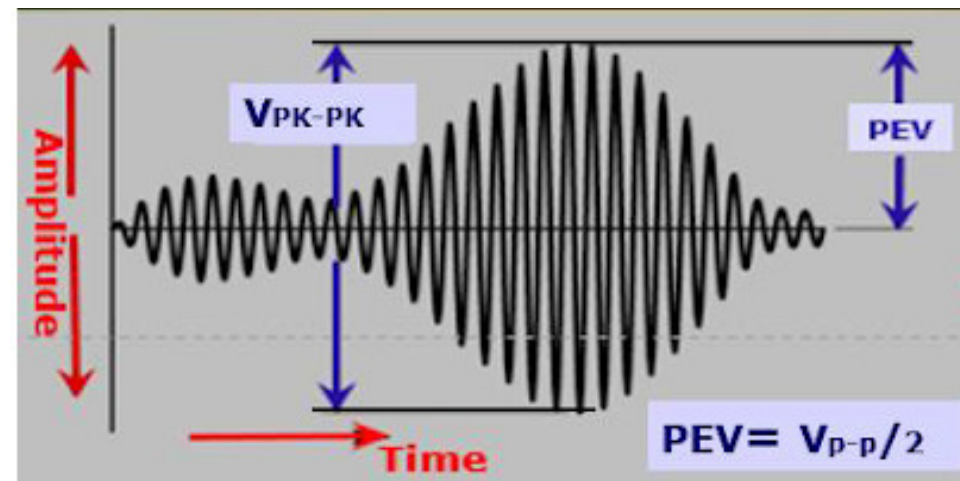

Clarification of Peak Envelope Power (cont.)

Once the RF cycle is identified, we calculate the average power over its complete duration. That's the **red** area in this figure.

Note that we calculate the power in both the positive voltage half-cycle and the negative voltage half-cycle. They don't cancel out because, as shown below, the PEP is squared, making both of them positive.

Start by measuring the amplitude of the peak, usually in volts. That is PEP in figure on previous slide.

Then apply the following formula ... (next slide) ...

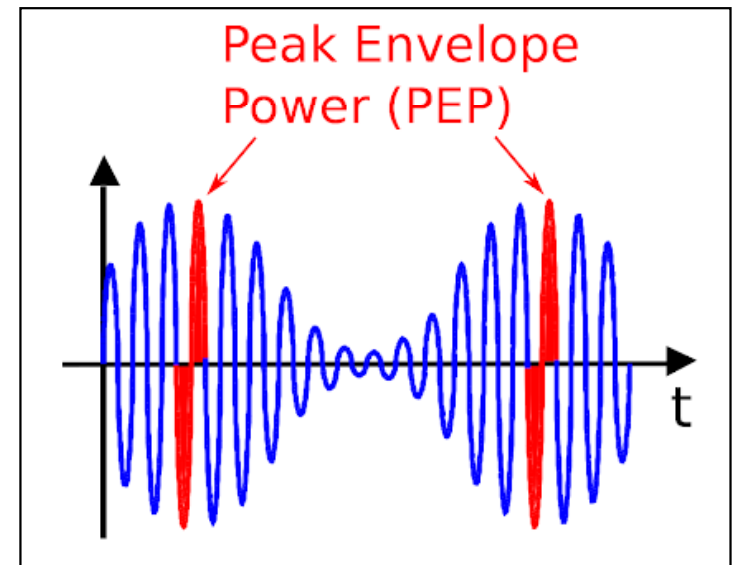

PEP Calculations

$$PEP = \frac{\left[\frac{V_{P-P}}{2} \times 0.707 \right]^2}{R} = \frac{(PEV \times 0.707)^2}{R} = \frac{V_{RMS}^2}{R}$$

Example: If PEV is 50V across a 50Ω load, the PEP power is ...

$$PEP = \frac{(50 \times 0.707)^2}{50} = \frac{35.35^2}{50} = \frac{1249.62}{50} = \mathbf{25W}$$

Example: If a 50Ω load is dissipating 1200W PEP, the RMS voltage is ...

$$V_{RMS} = \sqrt{PEP \times R} = \sqrt{1200 \times 50} = \mathbf{245V}$$

PEP Calculations (cont.)

If an oscilloscope measures 200 VP-P across a 50 Ω load, what would be the PEP power?

$$\text{PEP} = \frac{\left[\frac{0.707 \times 200}{2} \right]^2}{50} = \frac{4999}{50} = 100 \text{ W}$$

For the same device at 500 VP-P, the PEP power would be ...

$$\text{PEP} = \frac{\left[\frac{0.707 \times 500}{2} \right]^2}{50} = \frac{31241}{50} = 625 \text{ W}$$

PEP Summary

- PEP equals the average power IF an amplitude-modulated signal is NOT modulated
 - An example of this is when modulation is removed from an AM signal (leaving only the steady carrier) or when a CW transmitter is keyed
- An FM signal is a constant-power signal, so *PEP is always equal to average power for FM signals*. In other words, if an average-reading wattmeter connected to your transmitter reads 1060 W when you close the key on CW, your PEP output power will be ...

1060 W

PRACTICE QUESTIONS

What is the PEP produced by 200 volts peak-to-peak across a 50-ohm dummy load?

- A. 1.4 watts
- B. 100 watts
- C. 353.5 watts
- D. 400 watts

What value of an AC signal produces the same power dissipation in a resistor as a DC voltage of the same value?

- A. The peak-to-peak value
- B. The peak value
- C. The RMS value
- D. The reciprocal of the RMS value

What is the peak-to-peak voltage of a sine wave with an RMS voltage of 120 volts?

- A. 84.8 volts
- B. 169.7 volts
- C. 240.0 volts
- D. 339.4 volts

What is the RMS voltage of a sine wave with a value of 17 volts peak?

- A. 8.5 volts
- B. 12 volts
- C. 24 volts
- D. 34 volts

What is the ratio of PEP to average power for an unmodulated carrier?

- A. 0.707
- B. 1.00
- C. 1.414
- D. 2.00

What is the RMS voltage across a 50-ohm dummy load dissipating 1200 watts?

- A. 173 volts
- B. 245 volts
- C. 346 volts
- D. 692 volts

What is the output PEP of an unmodulated carrier if the average power is 1060 watts?

- A. 530 watts
- B. 1060 watts
- C. 1500 watts
- D. 2120 watts

What is the output PEP of 500 volts peak-to-peak across a 50-ohm load?

- A. 8.75 watts
- B. 625 watts
- C. 2500 watts
- D. 5000 watts

Section 4.3

Basic Components

- Refer to the following 5 slides ... selected basic component samples from Figure 4.4 (page 4-9 in your text)
- Three most basic components ...
 - Resistors: Designated with an R , resist flow of electricity, measured in ohms (Ω)
 - Capacitors: Designated C , store electric energy, measured in farads (F)
 - Inductors: Designated L , store magnetic energy, measured in henries (H)
- Typical values associated with components include; nominal value, tolerance, temperature coefficient, and power rating

Common Schematic Symbols: Resistors

Fig. 4.4

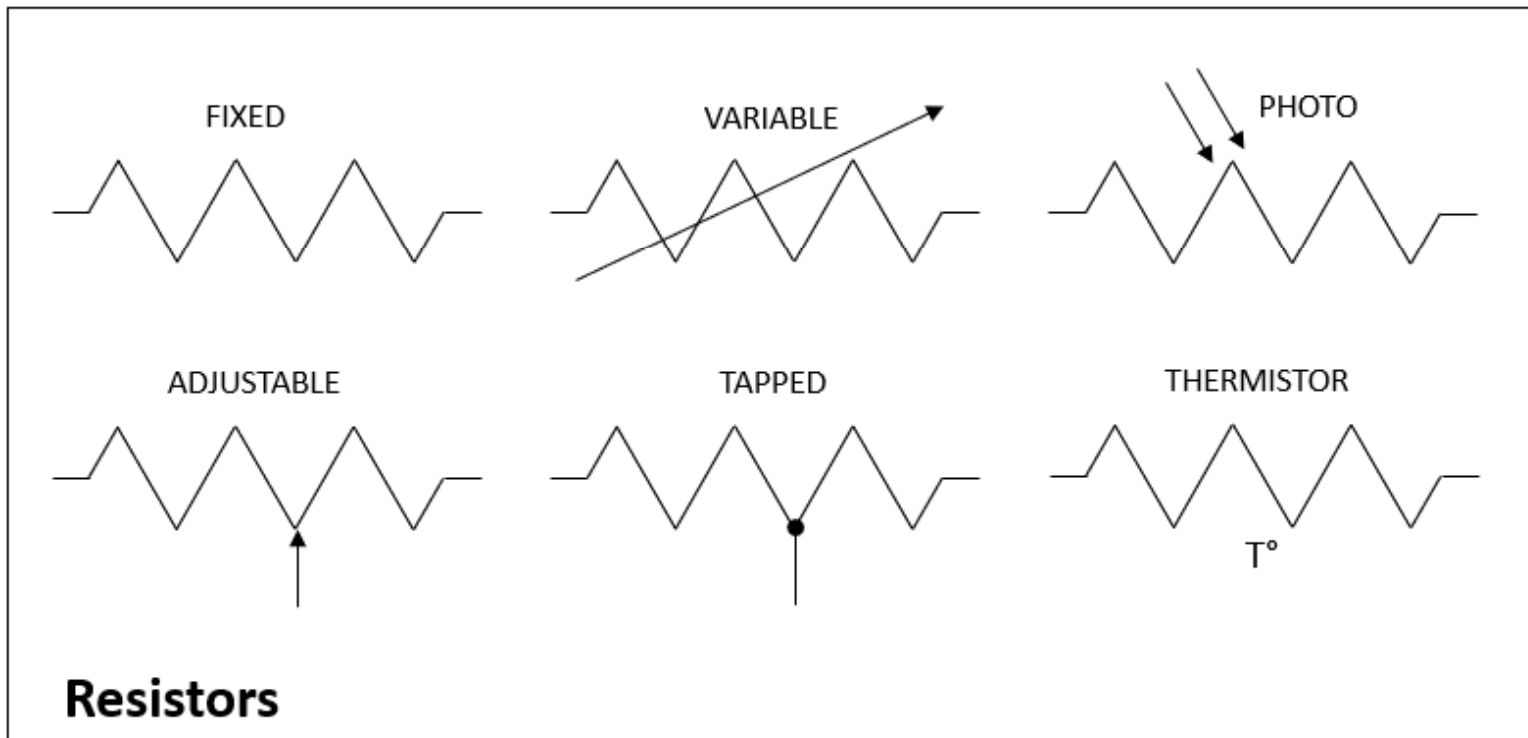

Common Schematic Symbols: Capacitors

Fig. 4.4

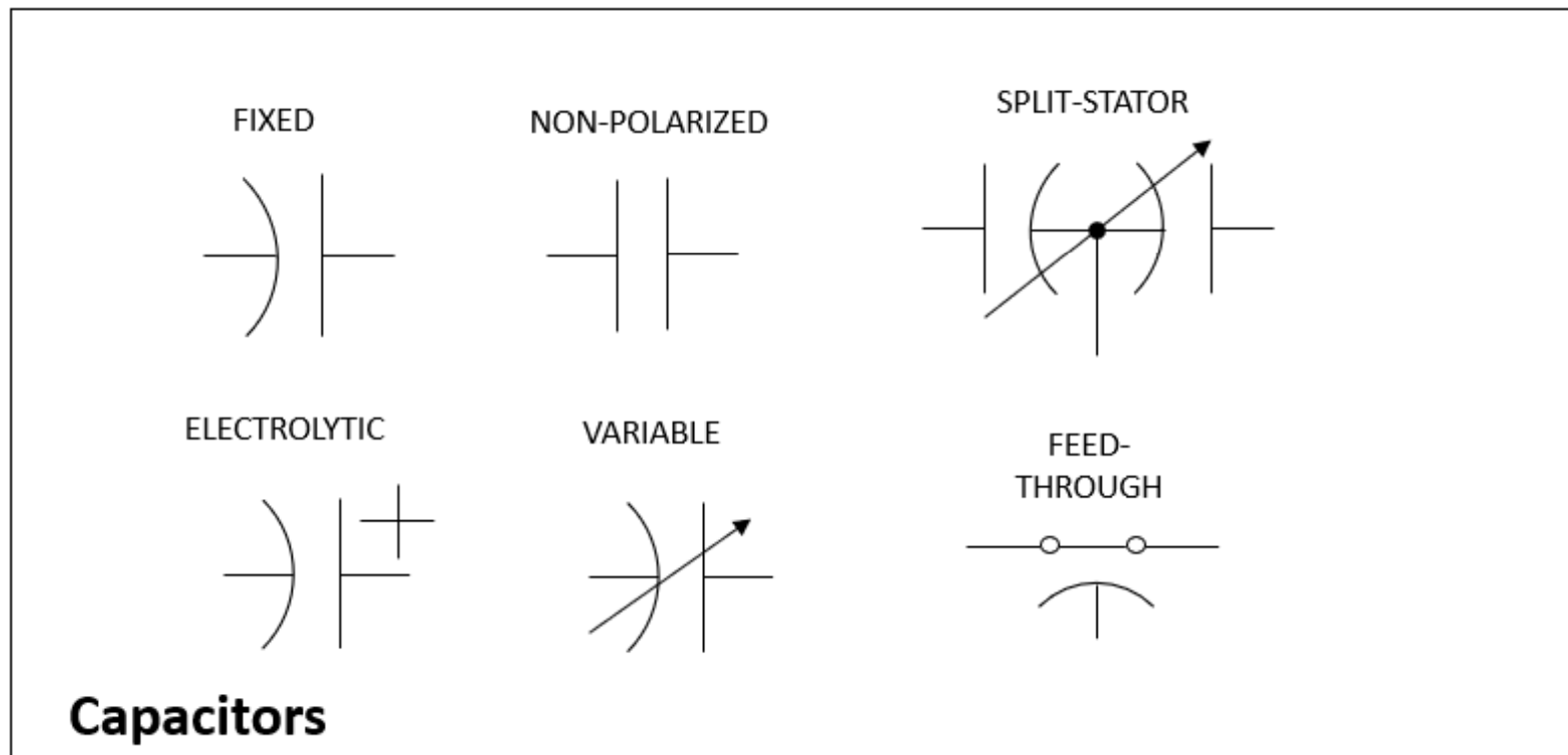

Common Schematic Symbols: Inductors

Fig. 4.4

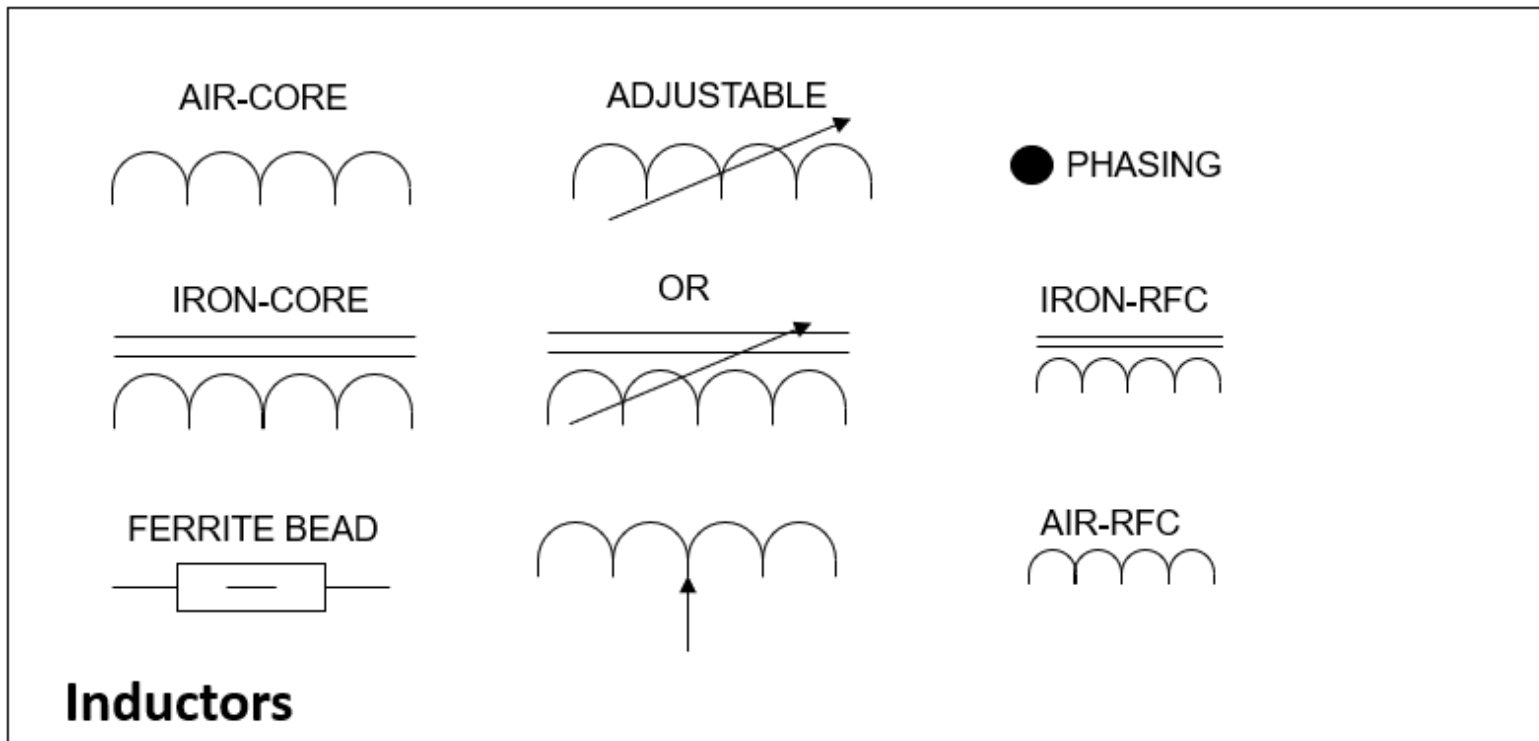

Common Schematic Symbols: Tubes

Fig. 4.4

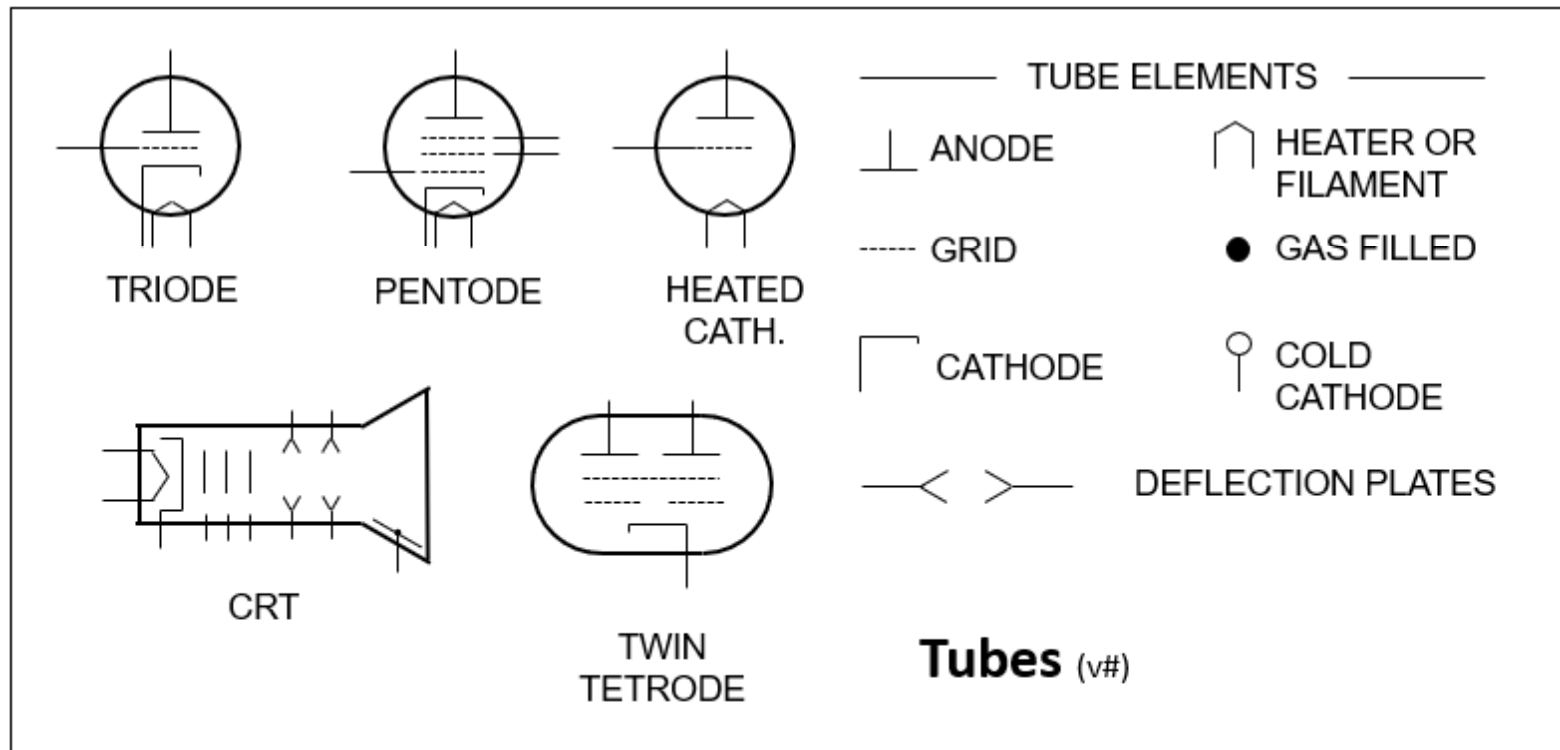

Common Schematic Symbols: **Wiring**

Fig. 4.4

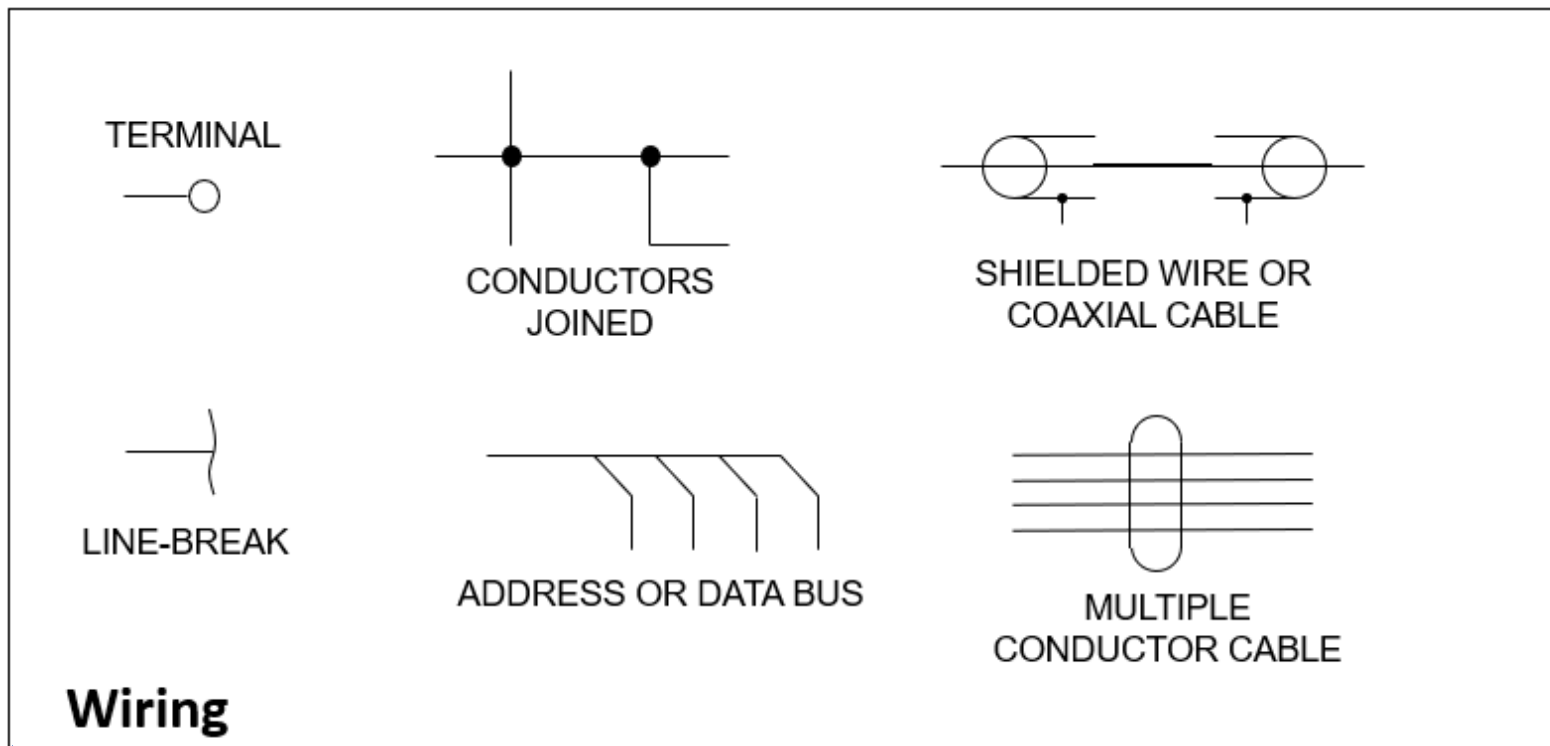

Resistors and Resistance

- Several common types
- Available with nominal values from 1Ω or less to more than $1M\Omega$
 - Nominal value printed with text or colored bands
 - Most common units are ohms (Ω), kilohms ($k\Omega$), and megohms ($M\Omega$)
- Precision tolerances range from 1% or less to 10%



Converting Between Units

CONVERT FROM	CONVERT TO (a)	CONVERT TO (b)
Ohms	Kilohms: Divide by 1000	Megohms: Divide by 1,000,000
Kilohms	Ohms: Multiply by 1000	Megohms: Divide by 1000
Megohms	Ohms: Multiply by 1,000,000	Kilohms: Multiply by 1000

EXAMPLE: $150 \Omega = 150 / 1000 = 0.15 \text{ k}\Omega$ and $150 \Omega = 150 / 1,000,000 = 0.00015 \text{ M}\Omega$

EXAMPLE: $4.7 \text{ k}\Omega = 4.7 \times 1000 = 4700 \Omega$ and $4.7 \text{ k}\Omega = 4.7 / 1000 = .00047 \text{ M}\Omega$

EXAMPLE: $2.2 \text{ M}\Omega = 2.2 \times 1,000,000 = 2,200,000 \Omega$ and $2.2 \text{ M}\Omega = 2.2 \times 1000 = 2200 \text{ k}\Omega$

Inductors and Inductance

- Like resistors, several common types
- Double lines indicate a solid magnetic core
- Variable inductors often have solid cores (use of double lines on schematics is optional)
- Miniature inductors (not shown here) look similar to resistors

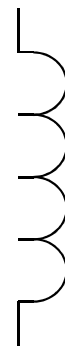
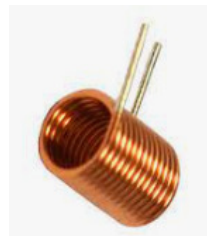

AIR-CORE

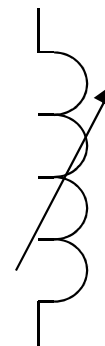

VARIABLE

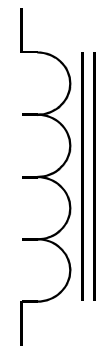

MAGNETIC
OR IRON
CORE

Inductor Design

- Inductance (ability to store magnetic energy) is directly proportional to the square of the number of turns and area enclosed by each turn
 - Making an inductor **LONGER** without changing number of turns or diameter **REDUCES** inductance
- Increasing the ability to store magnetic energy (called *permeability*) increases the inductance

Inductor Design (cont.)

- The type of core and winding affects inductance and vary according to the use/purpose of the inductor
- Variable inductors are often used in low-power receiving and transmitting applications
 - Adjusted by moving a magnetic core in and out of the inductor (threaded cores move when turned)
 - For high-power inductors, adjustment is made by moving a sliding contact along the inductor

Converting Between Units

CONVERT FROM	CONVERT TO	CONVERT TO
Nanohenries	Microhenries: Divide by 1000	Millihenries: Divide by 1,000,000
Microhenries	Nanohenries: Multiply by 1000	Millihenries: Divide by 1000
Millihenries	Nanohenries: Multiply by 1,000,000	Microhenries: Multiply by 1000

EXAMPLE: $330 \text{ nH} = 330 / 1000 = 0.33 \text{ } \mu\text{H}$ and $330 \text{ nH} = 330 / 1,000,000 = 0.00033 \text{ mH}$

EXAMPLE: $6.8 \text{ } \mu\text{H} = 6.8 \times 1000 = 6800 \text{ nH}$ and $6.8 \text{ } \mu\text{H} = 6.8 / 1000 = .0068 \text{ mH}$

EXAMPLE: $88 \text{ mH} = 88 \times 1,000,000 = 88,000,000 \text{ nH}$ and $88 \text{ mH} = 88 \times 1000 = 8800 \text{ } \mu\text{H}$

Inductor Coupling

- Place 2 inductors close together with axes aligned
- Magnetic field from one inductor can also pass through the second one, sharing some of its energy
- This is called *coupling*
- The ability of inductors to share or transfer magnetic energy is called *mutual inductance*

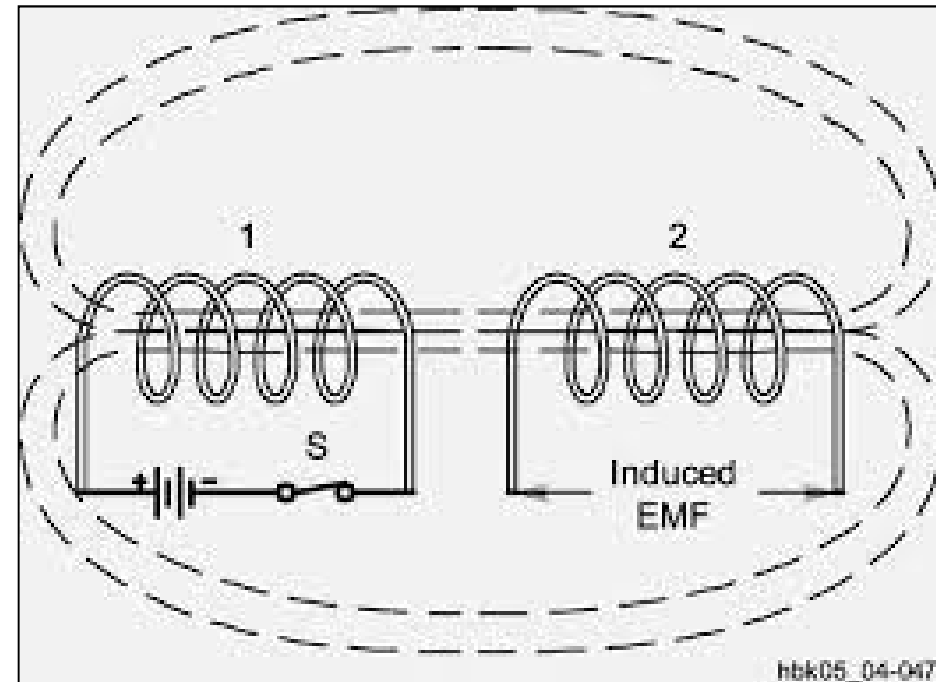

Inductor Design (cont.)



- In toroidal winding the core contains nearly all the inductor's magnetic field
- Since little of the field extends outside the core, toroids can be placed next to each other (in almost any orientation) with minimal mutual inductance
 - This property is useful in RF circuits
- Composition of the core varies (ferrite, powdered iron, even exotic “rare earth” metals), makes it possible to obtain wide range of inductance values in a relatively small package
- The combination of core materials (“mix”) is selected so the inductor performs best over a specific range of frequencies

PRACTICE QUESTIONS

Which symbol in figure G7-1 represents a field effect transistor?

- A. Symbol 2
- B. Symbol 5
- C. Symbol 1
- D. Symbol 4

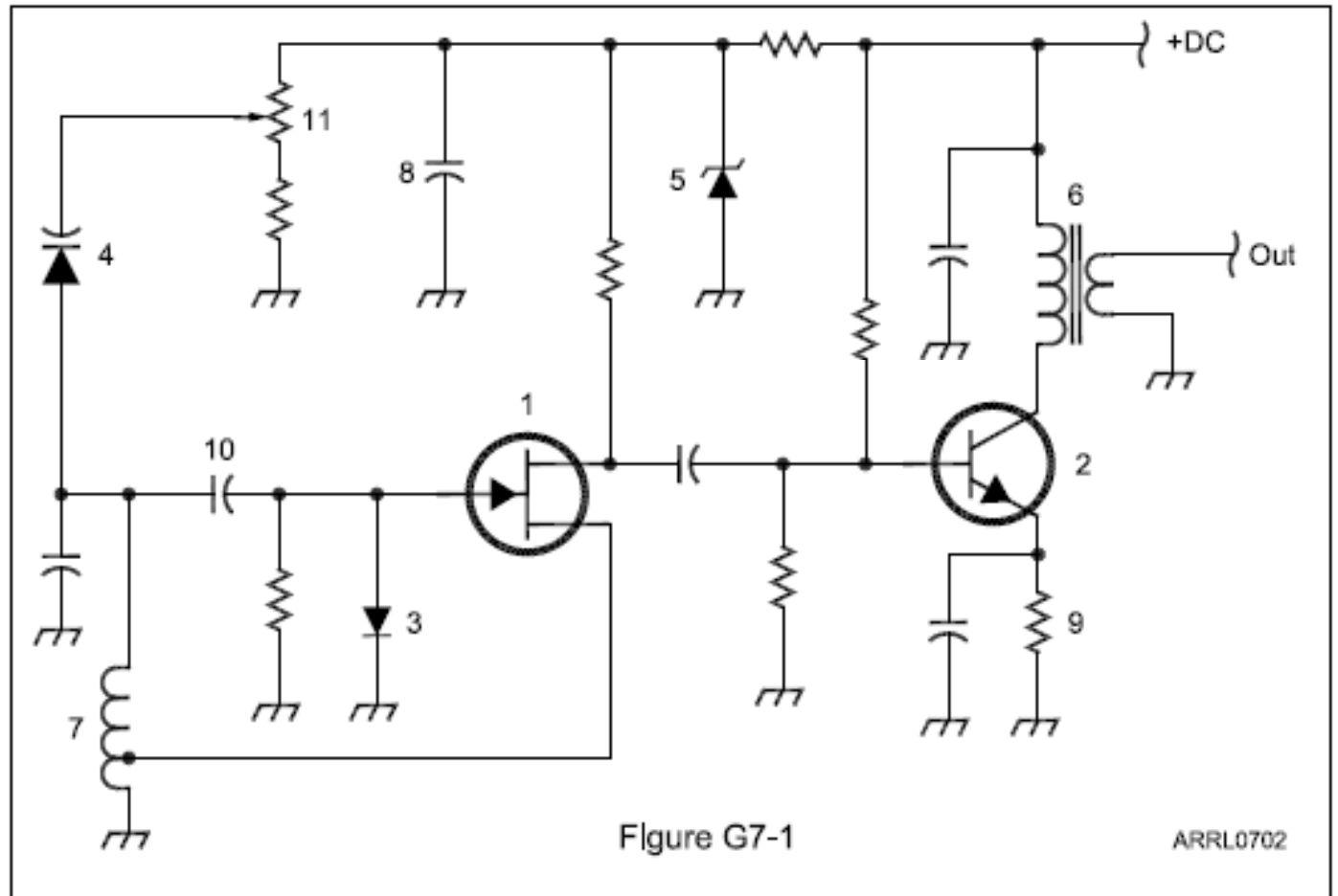

Which symbol in figure G7-1 represents a Zener diode?

- A. Symbol 4
- B. Symbol 1
- C. Symbol 11
- D. Symbol 5

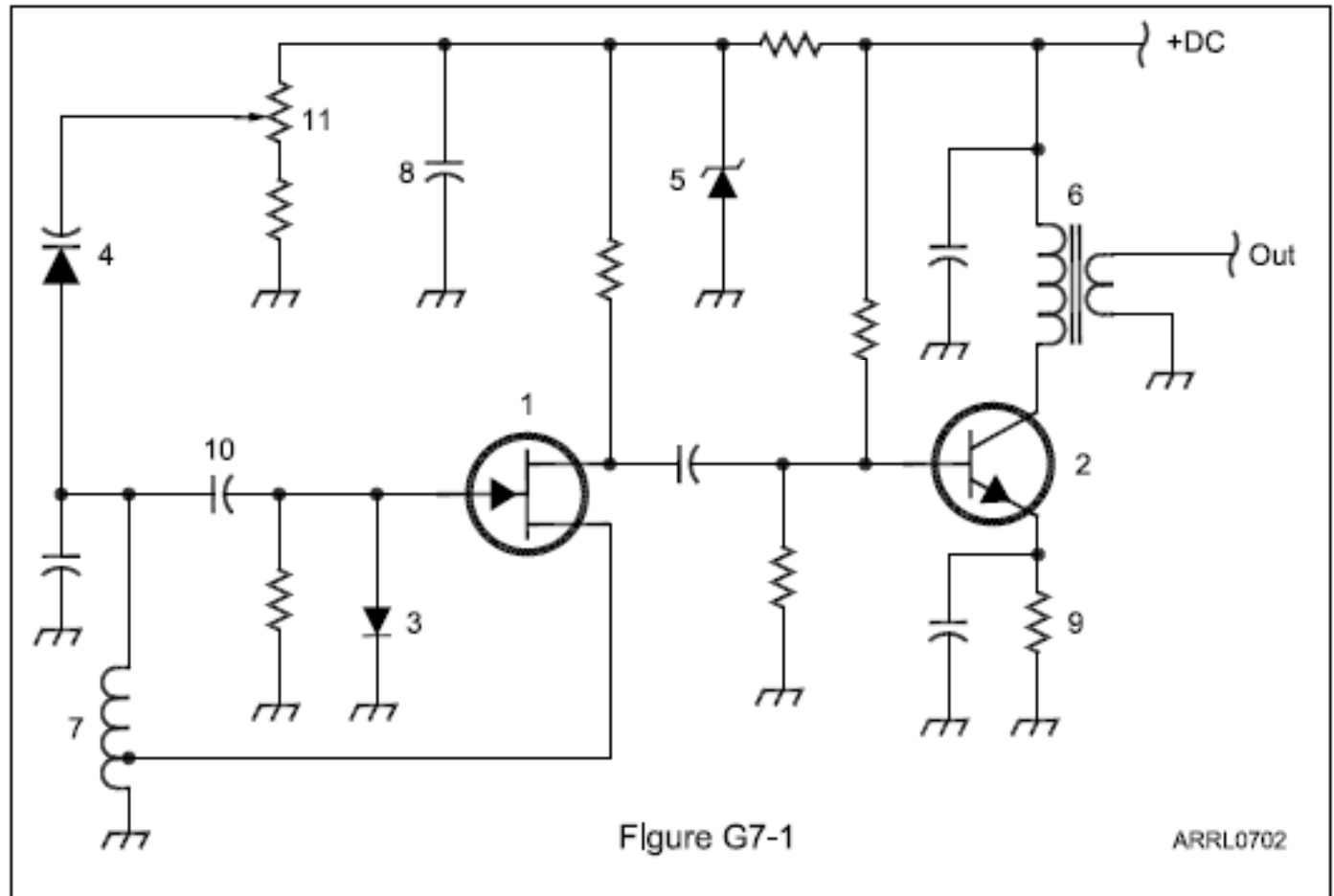

Which symbol in figure G7-1 represents an NPN junction transistor?

- A. Symbol 1
- B. Symbol 2
- C. Symbol 7
- D. Symbol 11

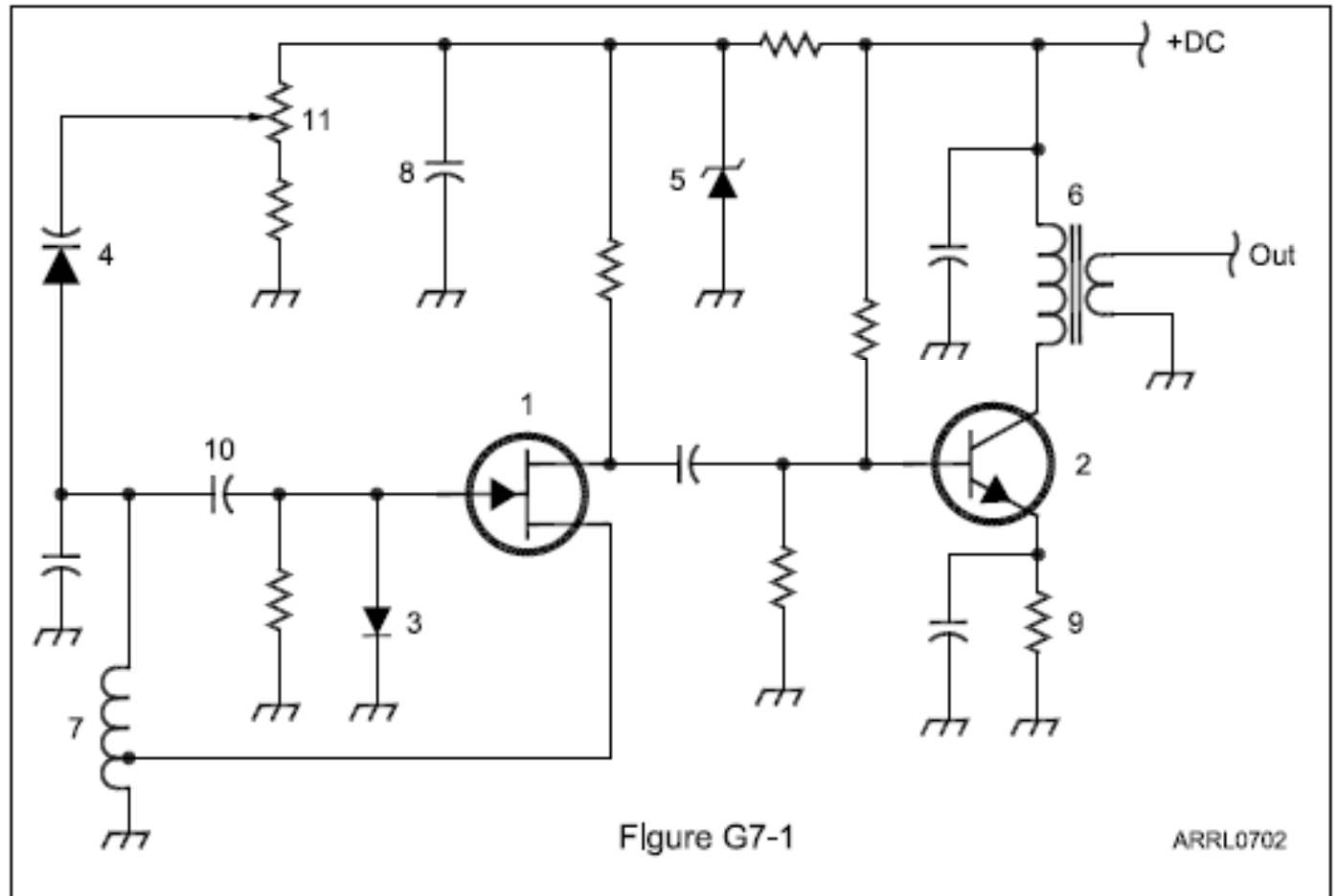

Which symbol in figure G7-1 represents a solid core transformer?

- A. Symbol 4
- B. Symbol 7
- C. Symbol 6
- D. Symbol 1

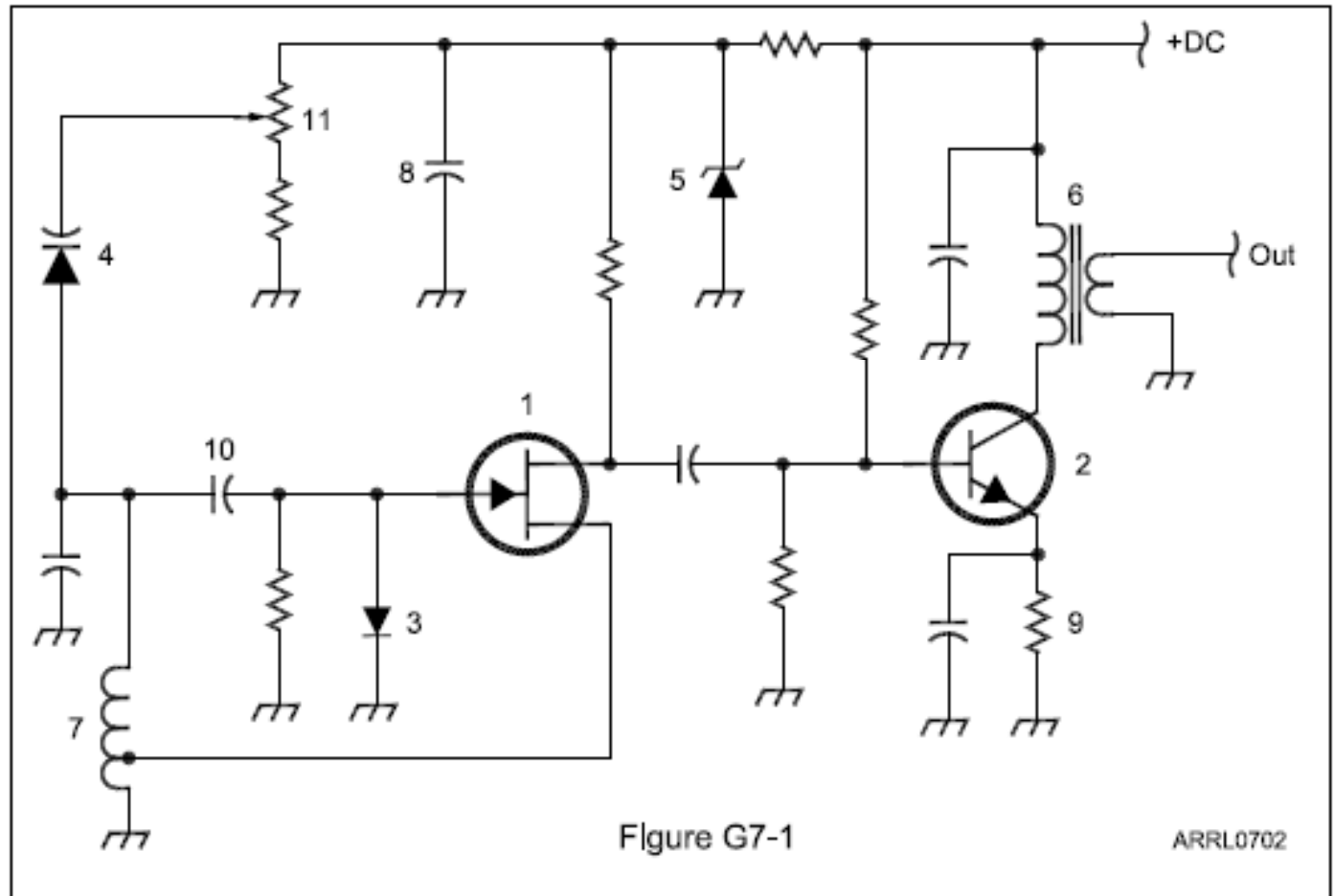

Which symbol in figure G7-1 represents a tapped inductor?

- A. Symbol 7
- B. Symbol 11
- C. Symbol 6
- D. Symbol 1

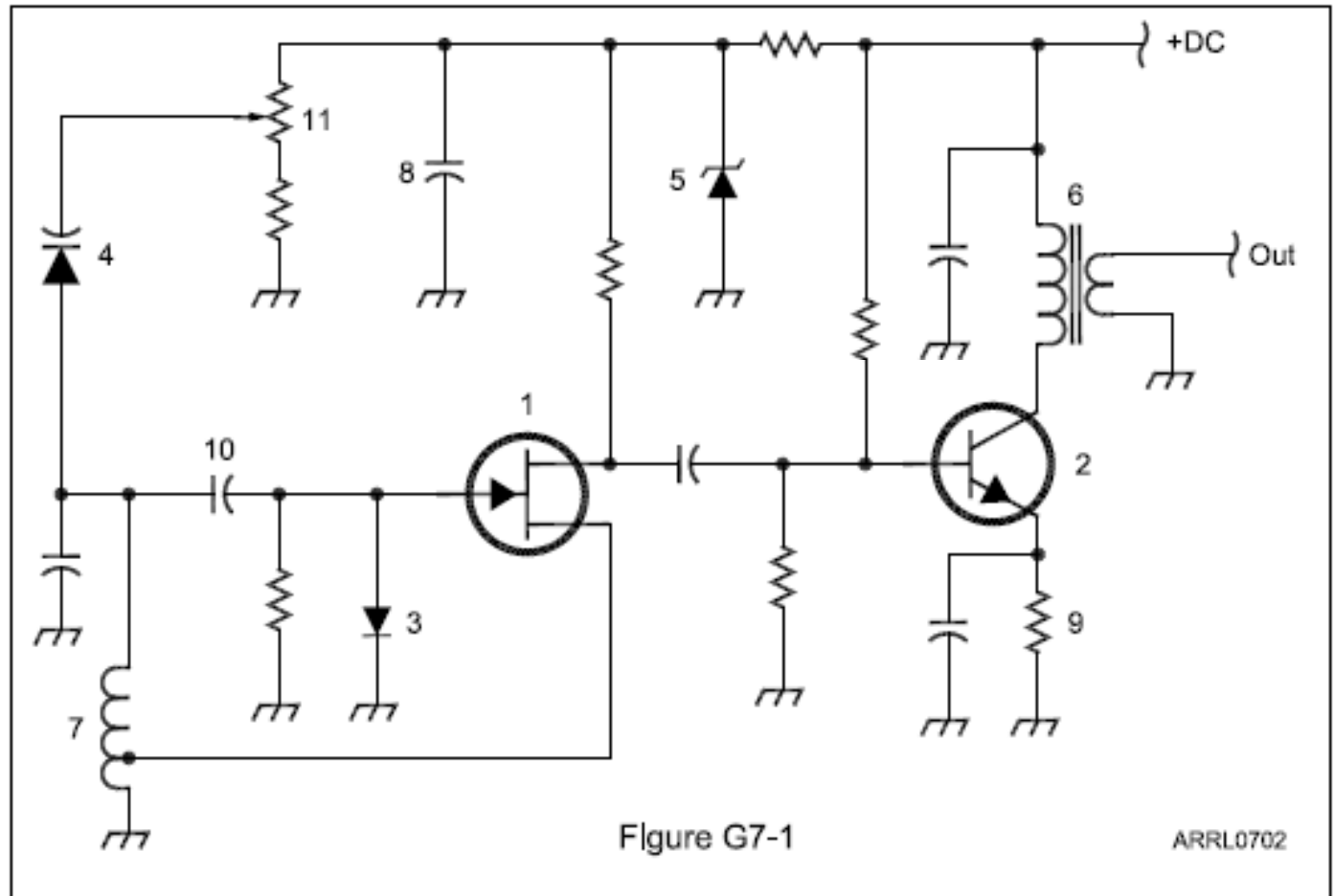

Figure G7-1

ARRL0702

What determines the performance of a ferrite core at different frequencies?

- A. Its conductivity
- B. Its thickness
- C. The composition, or “mix,” of materials used
- D. The ratio of outer diameter to inner diameter

What is an advantage of using a ferrite core toroidal inductor?

- A. Large values of inductance may be obtained
- B. The magnetic properties of the core may be optimized for a specific range of frequencies
- C. Most of the magnetic field is contained in the core
- D. All these choices are correct

Capacitors and Capacitance

- Capacitors have two conducting surfaces (*electrodes*) separated by a *dielectric*
- Capacitance is the ability to store electric energy, measured in *farads* (F)
- Blocks dc current flow
- The simplest capacitor is a pair of metal plates separated by air
- Increase capacitance by increasing surface areas, moving surfaces closer together, or changing dielectric material

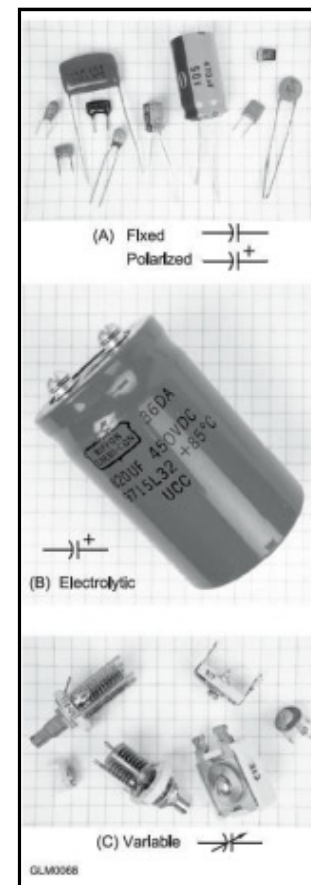

Capacitors and Capacitance (cont.)

- Tantalum and electrolytic capacitors are *polarized*, meaning the dc voltage may only be applied on one direction without damaging the electrolyte (check polarity markings for correct installation)
- Capacitors have *voltage ratings*; exceeding this rating can result in arcing between conducting surfaces (usually destroys all but air-dielectric capacitors)

Capacitors and Capacitance (cont.)

- Capacitor types:
 - Ceramic – RF filtering and bypassing at high frequencies, low cost
 - Plastic film – audio circuits & lower radio frequencies
 - Silvered-mica – highly stable, low loss, used in RF circuits
 - Electrolytic and tantalum – power supply filter circuits
 - Air and vacuum dielectric – transmitting and RF circuits

Capacitors and Capacitance (cont.)

- Capacitor uses:
 - Blocking – pass ac signals while blocking dc signals
 - Bypass – provide low impedance path for ac signals around higher-impedance circuit
 - Filter – smooth out voltage pulses of rectified ac to an even dc voltage
 - Suppressor – absorb energy of voltage transients or spikes
 - Tuning – vary frequency of resonant circuits or adjust impedance matching circuits

Aluminum and Tantalum Electrolytic Capacitors

- Designed to optimize their energy storage capabilities
- Voltage must be applied with the correct polarity
- Creates large capacitances in comparatively small volumes
- Aluminum: Uses metal foil for conducting surfaces and dielectric is an insulating layer on the foil created by a wet paste or gel
- Tantalum: Similar to aluminum in that a porous mass of tantalum is immersed in an electrolyte

PRACTICE QUESTIONS

Which of the following is characteristic of an electrolytic capacitor?

- A. Tight tolerance
- B. Much less leakage than any other type
- C. High capacitance for a given volume
- D. Inexpensive RF capacitor

Which of the following is characteristic of low voltage ceramic capacitors?

- A. Tight tolerance
- B. High stability
- C. High capacitance for given volume
- D. Comparatively low cost

Transformers

- Transformers transfer ac power between 2 or more inductors (called *windings*) sharing a common core
- The winding **TO** which power is applied is the *primary*
- The winding **FROM** which power is supplied is the *secondary*
- When voltage is applied to primary, mutual inductance causes voltage to appear across secondary
- Transformers work in “both directions” (*step-up* and *step-down*)

Transformers (cont.)

- Transformers change power from one combination of ac voltage and current to another by using windings with different numbers of turns
 - The transformation occurs because all windings share the same magnetic field (wound on the same core)
- A significant change between secondary & primary usually requires a change in wire size between windings
 - In step-up transformers, the primary carries higher current and is wound with larger diameter wire than the secondary

Transformer “Math”

- The ratio of number turns in the primary winding (N_p) to the number of turns in the secondary (N_s) determines how current and voltage are changed
- Since most circuits are concerned with voltage, most transformer equations relate transformer input (primary) voltage (E_p) to output (secondary) voltage (E_s)

$$\frac{E_s}{E_p} = \frac{N_s}{N_p} \quad \text{OR} \quad E_s = E_p \times \frac{N_s}{N_p}$$

Transformer “Math” Examples

What is the voltage across a 1500-turn secondary winding if 120 V ac is applied across the 500 turn primary winding?

$$E_s = E_p \times \frac{N_s}{N_p} = 120 \times \frac{1500}{500} = 120 \times 3 = 360 \text{ V ac}$$

Transformer “Math” Examples (cont.)

What would be the secondary-to-primary turns ratio to change 115V ac to 500V ac?

$$\frac{E_S}{E_P} = \frac{N_S}{N_P} \quad \dots \text{ is the same as } \dots \quad \frac{N_S}{N_P} = \frac{E_S}{E_P}$$

$$\frac{N_S}{N_P} = \frac{E_S}{E_P} = \frac{500}{115} = 4.35$$

Transformer “Math” Examples (cont.)

What happens if a signal is applied to the secondary winding of a 4:1 transformer instead of the primary?

In the previous formula, reverse E_p and E_s .

A 4:1 transformer has 4 times the number of turns in the primary than secondary. Applying the signal to the secondary will increase the voltage proportionally ... 4 times the input voltage.

PRACTICE QUESTIONS

What causes a voltage to appear across the secondary winding of a transformer when an AC voltage source is connected across its primary winding?

- A. Capacitive coupling
- B. Displacement current coupling
- C. Mutual inductance
- D. Mutual capacitance

What is the output voltage if an input signal is applied to the secondary winding of a 4:1 voltage step-down transformer instead of the primary winding?

- A. The input voltage is multiplied by 4
- B. The input voltage is divided by 4
- C. Additional resistance must be added in series with the primary to prevent overload
- D. Additional resistance must be added in parallel with the secondary to prevent overload

Why is the primary winding wire of a voltage step-up transformer usually a larger size than that of the secondary winding?

- A. To improve the coupling between the primary and secondary
- B. To accommodate the higher current of the primary
- C. To prevent parasitic oscillations due to resistive losses in the primary
- D. To ensure that the volume of the primary winding is equal to the volume of the secondary winding

What is the voltage output of a transformer with a 500-turn primary and a 1500-turn secondary when 120 VAC is applied to the primary?

- A. 360 volts
- B. 120 volts
- C. 40 volts
- D. 25.5 volts

Components in Series and Parallel Circuits

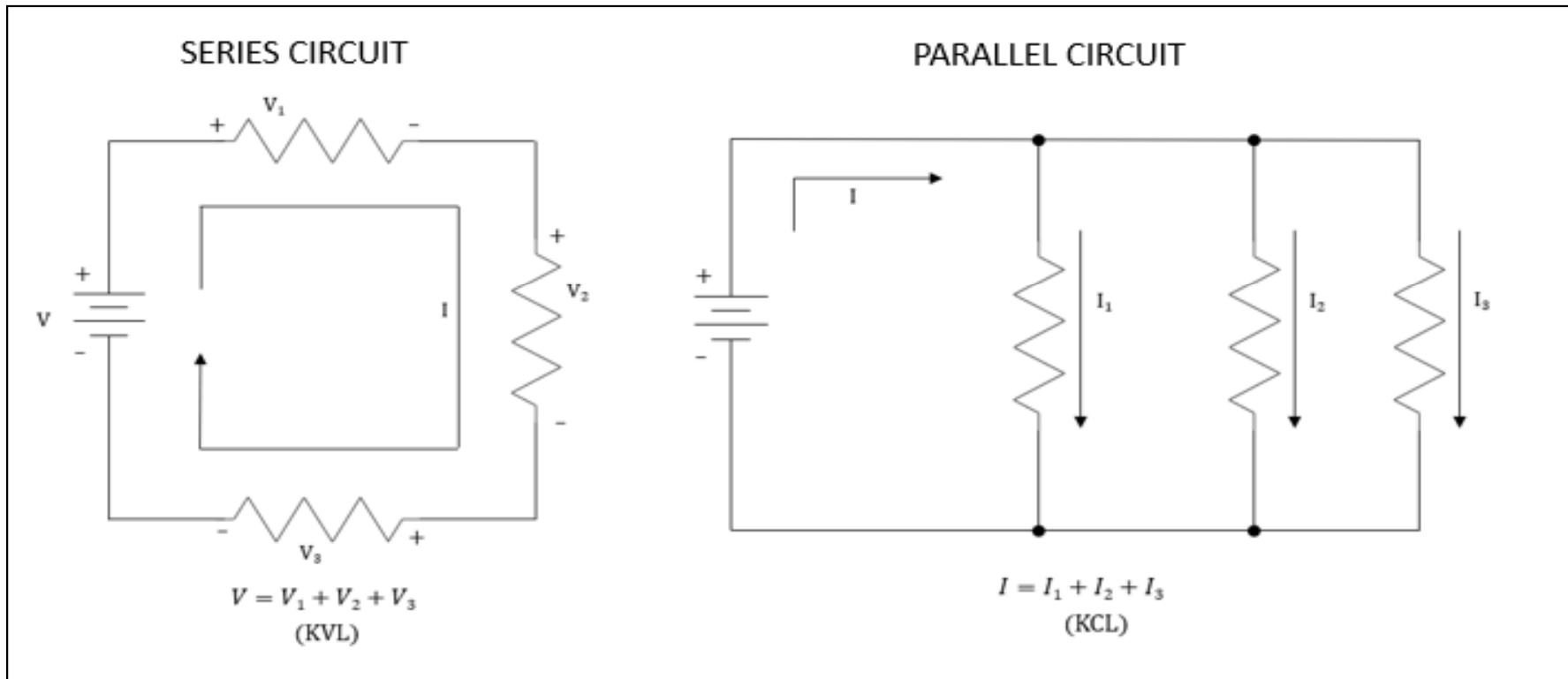

Components in Series and Parallel Circuits

- In series circuits, the current is the same in all components and voltages are summed (*Kirchoff's Voltage Law – KVL*).
 - Voltages add in a series circuit
- In parallel circuits, voltage across all components is the same and the sum of currents into and out of circuit junctions must be equal (*Kirchoff's Current Law – KCL*).
 - Currents add in a parallel circuit
- Components connected in series or parallel can be replaced with a single *equivalent* component

Calculating Series & Parallel Equivalent Values

COMPONENT	IN SERIES
RESISTOR	ADD VALUES, $R1 + R2 + R3 + \dots$
INDUCTOR	ADD VALUES, $L1 + L2 + L3 + \dots$
CAPACITOR	RECIPROCAL OF RECIPROCAL, $1/(1/C1 + 1/C2 + 1/C3 + \dots)$

COMPONENT	IN PARALLEL
RESISTOR	RECIPROCAL OF RECIPROCAL, $1/(1/R1 + 1/R2 + 1/R3 + \dots)$
INDUCTOR	RECIPROCAL OF RECIPROCAL, $1/(1/L1 + 1/L2 + 1/L3 + \dots)$
CAPACITOR	ADD VALUES, $C1 + C2 + C3 + \dots$

Refer to Figure 4.10 & Tables 4.2, 4.3

Effect on Total Value of Adding Components in Series and Parallel

COMPONENT	ADDING IN SERIES	ADDING IN PARALLEL
RESISTOR	INCREASE	DECREASE
INDUCTOR	INCREASE	DECREASE
CAPACITOR	DECREASE	INCREASE

Refer to Figure 4.10 & Tables 4.2, 4.3

Figure 4.10: Illustrates how components in series and parallel can be combined into a single equivalent component value.

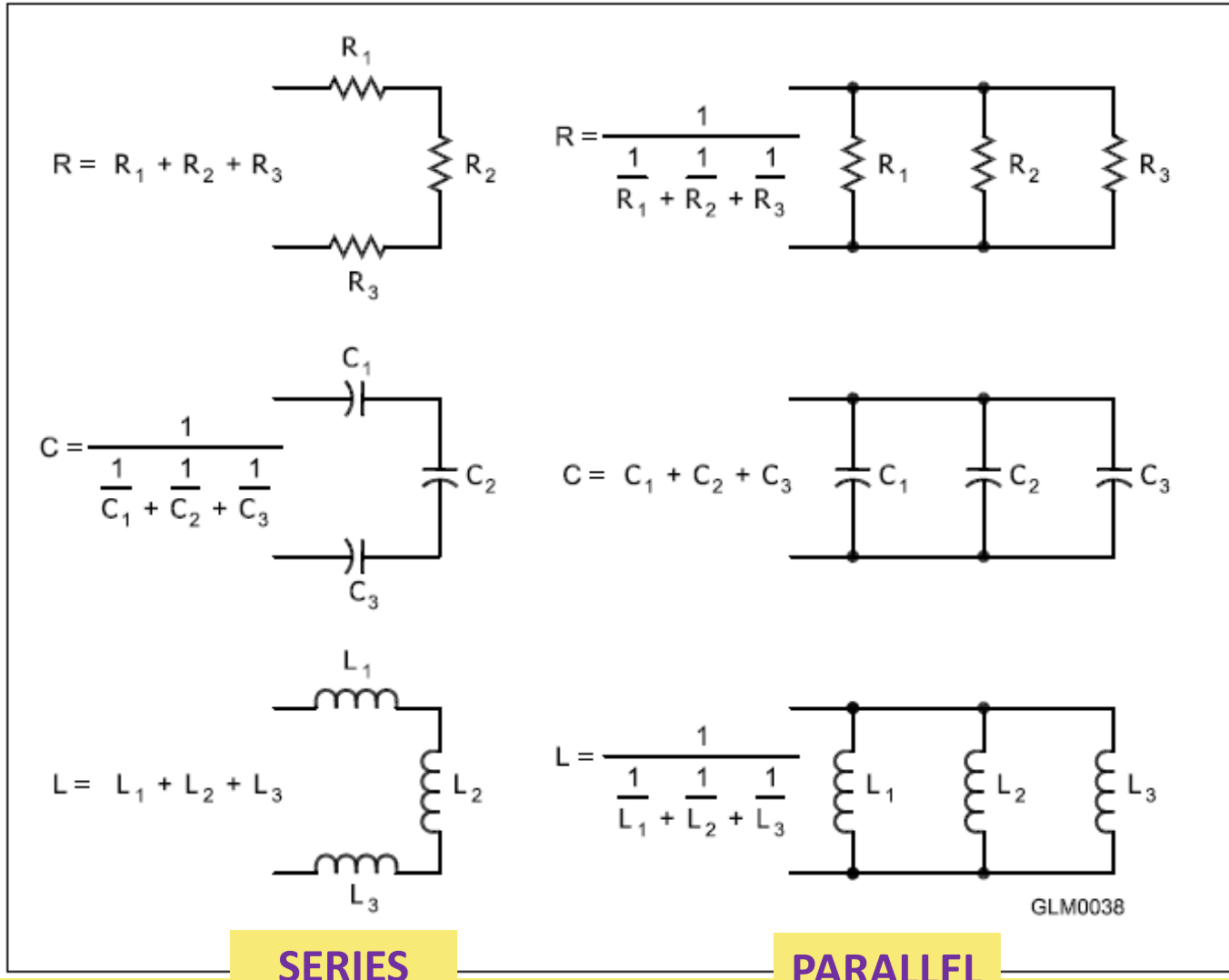

Examples: Calculating Series & Parallel Equivalent Values

Three 100 Ω resistors ...

In Series ... $R_{EQU} = 100 + 100 + 100 = 300 \Omega$

In Parallel ... $R_{EQU} = \frac{1}{\frac{1}{100} + \frac{1}{100} + \frac{1}{100}} = \frac{1}{\frac{3}{100}} = \frac{100}{3} = 33.3 \Omega$

Three 100 μF capacitors ...

In Series ... $C_{EQU} = \frac{1}{\frac{1}{100} + \frac{1}{100} + \frac{1}{100}} = \frac{1}{\frac{3}{100}} = \frac{100}{3} = 33.3 \mu\text{F}$

In Parallel ... $C_{EQU} = 100 + 100 + 100 = 300 \mu\text{F}$

Calculating Series & Parallel Equivalent Values (cont.)

With only two components, the *reciprocal of reciprocals* calculation is greatly simplified ...

$$R_{EQU} = \frac{R1 \times R2}{R1 + R2}$$

What is the approximate total resistance of a 100- and a 200-ohm resistor in parallel?

$$R_{EQU} = \frac{R1 \times R2}{R1 + R2} = \frac{100 \times 200}{100 + 200} = \frac{20,000}{300} = 66.67 \Omega$$

Inductance of a 20 mH and 50 mH inductor ...

In series ... $L_{EQU} = 20 + 50 = 70 \text{ mH}$

In parallel ... $L_{EQU} = \frac{L1 \times L2}{L1 + L2} = \frac{20 \times 50}{20 + 50} = 14.29 \text{ mH}$

Calculating Series & Parallel Equivalent Values (cont.)

What is the total inductance of three 10 mH inductors in **parallel**?

$$L_{EQU} = \frac{1}{\frac{1}{10} + \frac{1}{10} + \frac{1}{10}} = \frac{10}{3} = 3.3 \text{ mH}$$

What is the total inductance of three 10 mH inductors in **series**?

$$L_{EOU} = 10 + 10 + 10 = 30 \text{ mH}$$

Calculating Series & Parallel Equivalent Values (cont.)

What is the total capacitance of two 5 nF and one 750 pF capacitors in **series**?

Note that the capacitors aren't in the same units! First convert 5 nF to pF ...

$$5 \text{ nF} \times 1,000 = 5,000 \text{ pF}$$

$$C_{EQU} = \frac{1}{\frac{1}{C_1} + \frac{1}{C_2} + \frac{1}{C_3}} = \frac{1}{\frac{1}{5000} + \frac{1}{5000} + \frac{1}{750}} = \frac{1}{0.0002 + 0.0002 + 0.00133} = \frac{1}{0.001733} = 577 \text{ pF}$$

And, in **parallel**?

$$C_{EQU} = C_1 + C_2 + C_3 = 5000 + 5000 + 750 = 10750 \text{ pF} = 10.75 \text{ nF}$$

PRACTICE QUESTIONS

How does the total current relate to the individual currents in a circuit of parallel resistors?

- A. It equals the average of the branch currents
- B. It decreases as more parallel branches are added to the circuit
- C. It equals the sum of the currents through each branch
- D. It is the sum of the reciprocal of each individual voltage drop

What is the total resistance of a 10-, a 20-, and a 50-ohm resistor connected in parallel?

- A. 5.9 ohms
- B. 0.17 ohms
- C. 17 ohms
- D. 80 ohms

What is the approximate total resistance of a 100- and a 200-ohm resistor in parallel?

- A. 300 ohms
- B. 150 ohms
- C. 75 ohms
- D. 67 ohms

What is the equivalent capacitance of two 5.0-nanofarad capacitors and one 750-picofarad capacitor connected in parallel?

- A. 576.9 nanofarads
- B. 1,733 picofarads
- C. 3,583 picofarads
- D. 10.750 nanofarads

What is the capacitance of three 100-microfarad capacitors connected in series?

- A. 0.33 microfarads
- B. 3.0 microfarads
- C. 33.3 microfarads
- D. 300 microfarads

What is the inductance of three 10-millihenry inductors connected in parallel?

- A. 0.30 henries
- B. 3.3 henries
- C. 3.3 millihenries
- D. 30 millihenries

What is the inductance of a circuit with a 20-millihenry inductor connected in series with a 50-millihenry inductor?

- A. 7 millihenries
- B. 14.3 millihenries
- C. 70 millihenries
- D. 1,000 millihenries

What is the capacitance of a 20-microfarad capacitor connected in series with a 50-microfarad capacitor?

- A. 0.07 microfarads
- B. 14.3 microfarads
- C. 70 microfarads
- D. 1,000 microfarads

Which of the following components should be added to a capacitor to increase the capacitance?

- A. An inductor in series
- B. An inductor in parallel
- C. A capacitor in parallel
- D. A capacitor in series

Which of the following components should be added to an inductor to increase the inductance?

- A. A capacitor in series
- B. A resistor in parallel
- C. An inductor in parallel
- D. An inductor in series

END OF CHAPTER 4 PART 1 of 3

Slides created by ...

Jerry D. Kilpatrick

KØILP (Amateur Radio)

PGØØØ72373 (Commercial Operator)

KØILP.NC@gmail.com

Feel free to contact me if you find errors or have suggestions for improvement.