

THE ARRL

TENTH  
EDITION

# GENERAL

LICENSE COURSE **FOR**  
**HAM**

**All You Need to Pass Your General Class Exam!**

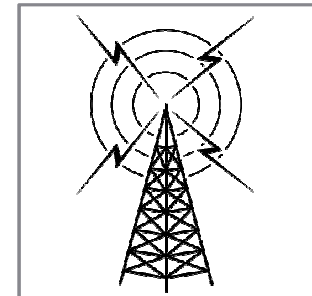
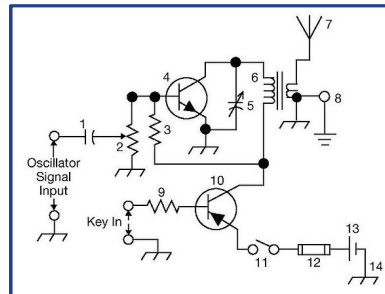

# Resource & Reference

[www.arrl.org/shop/Licensing-Education-and-Training](http://www.arrl.org/shop/Licensing-Education-and-Training)

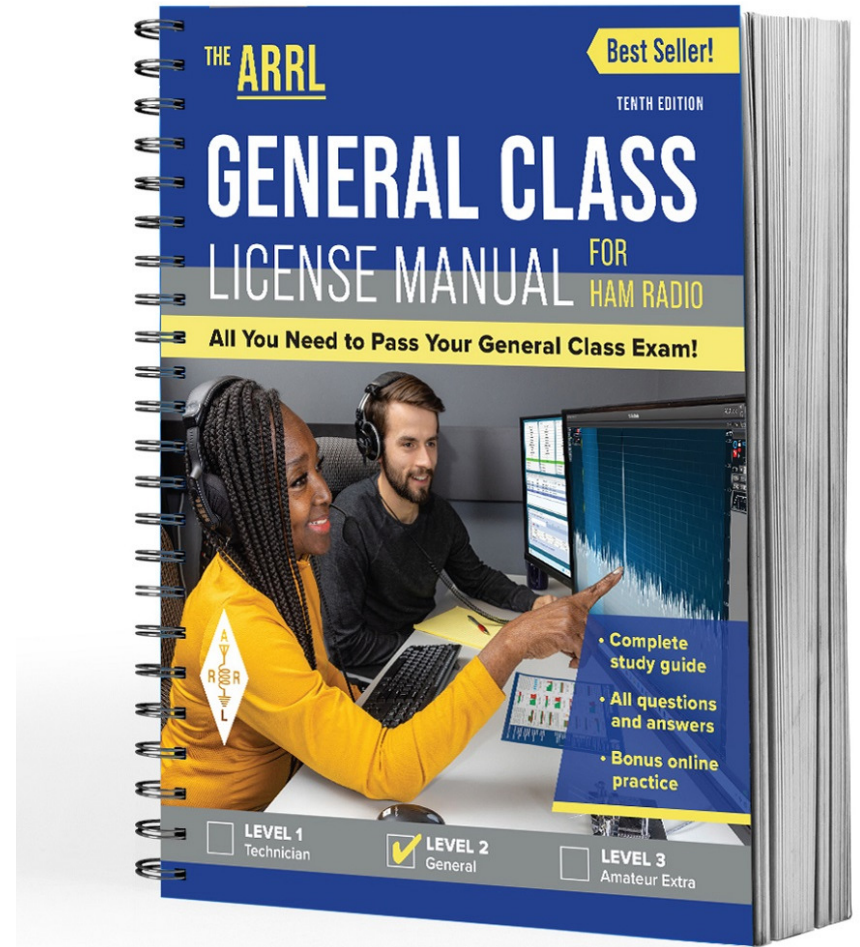

# Chapter 5 Part 2 of 2

ARRL General Class  
Radio Signals & Equipment  
Sections 5.4, 5.5

Receivers, HF Station Installation

# Section 5.4

## Superheterodyne Receivers

- Most receivers used by today's amateurs are *superheterodyne*
- Received signals are incredibly weak – on the order of nano or picowatts
  - Received signals are first strengthened by the *RF amplifier*, then applied to the RF input of a mixer
  - The *local oscillator* (LO) is adjusted so that the desired signal creates a mixing product at the *intermediate frequency* (IF)
  - A *detector* or *demodulator* stage follows the IF to recover the modulating information
  - Input amplifier gain, demodulator stage bandwidth, and input amplifier noise can all affect receiver sensitivity

# Fig. 5.16

A superheterodyne receiver converts signals to audio in two steps. The front end converts the frequency of a signal to the intermediate frequency (IF) where most of the gain of the receiver is provided. A second mixer – the product detector – converts the signal to audio frequencies.

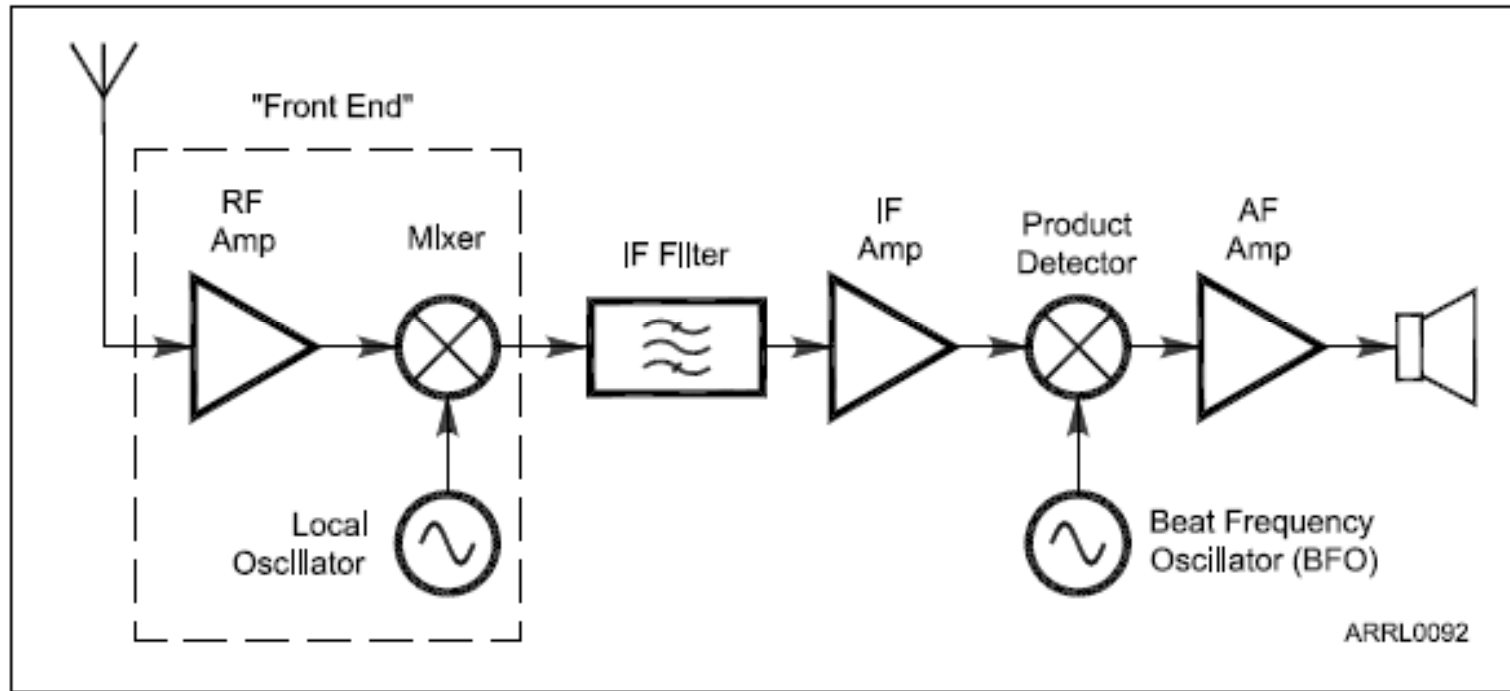

## Superheterodyne Receivers (cont.)

- Once amplified to a more usable level, SSB and CW signals are demodulated by a *product detector*, a special type of mixer
- If an AM signal is being received, a *product detector* or *envelope detector* recovers the modulating signal
- Output of the detector is an audio signal amplified by an audio frequency (AF) amplifier and input to a speaker, headphones, or sound card

# Superheterodyne Receivers (cont.)

- The RF amplifier and mixer are the receiver's front end
  - Processes weak signals at their original frequencies
  - A *preselector* is often used to reject *out-of-band* signals
  - A preamplifier (preamp) is used if additional sensitivity is needed (weak signals)

## Superheterodyne Receivers (cont.)

- The simplest possible *superhet* consists of a mixer connected to the antenna, an oscillator to act as the LO, and a detector that operates directly on the *resulting* IF signal ... See Figure 5.16
- The single-frequency IF stages make it much easier to create high quality filters and high gain amplifiers without having to be tuned. Only the LO needs to be tuned in a superhet receiver.
- Recall the formula for intermodulation (mixing of signals) ...  $f_1 \pm f_2$ 
  - For example, to convert an RF signal on 14.250 MHz to an IF of 455 kHz, the LO must be tuned to either  $14.250 - 455 \text{ kHz} = 13.795 \text{ MHz}$  or to  $14.250 + 455 \text{ kHz} = 14.705 \text{ MHz}$



# Superhets (cont.)

- Superhets have some weaknesses, like all radio designs
  - Because there are mixing products at both the sum and difference frequencies, undesired signals can create their own mixing products at the IF ... see next slide for examples (refer to Fig 5.4, explained in Chapter 5 Part 1)

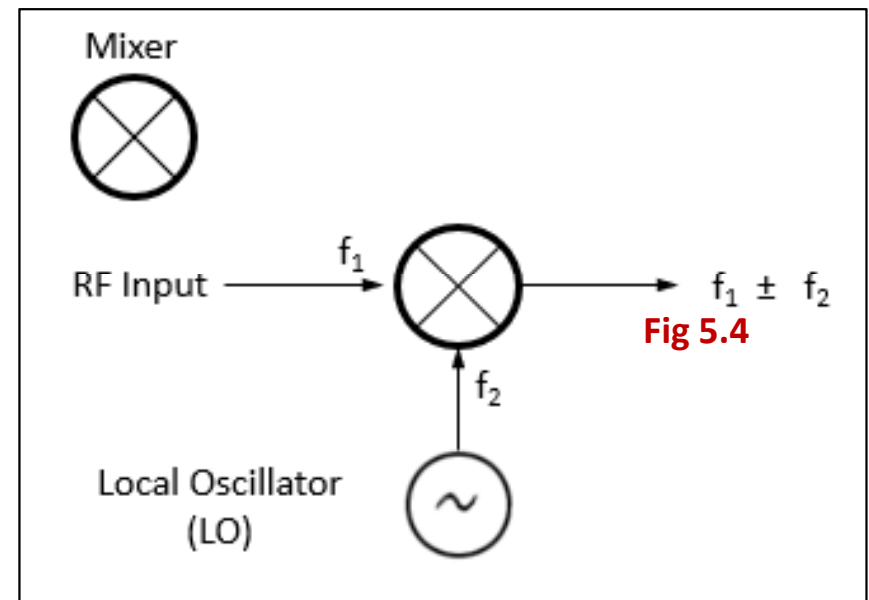

# Superhet (cont.)

- Another flaw is caused by the LO and other oscillator circuits. Leakage of signals into the signal path can cause steady signals to appear (called *birdies*).
- Fig. 5.16 shows a *single-conversion*, with only one mixer converting the signal from RF to IF
  - The IF stages provide most of the gain and selectivity
  - Filtering is applied at each IF (allows filter bandwidth selection for desired signal) ... this gives the best received signal quality with the lowest unwanted noise and interference, maximizing the *signal-to-noise ratio* (SNR)

# Superhet Mixer Weakness Example (see Fig 5.4)

In a mixer, with an RF Input or Input Frequency ( $f_1$ ) and Local Oscillator ( $f_2$ ), remember there are mixing products at ...

$$f_1 \pm f_2 \text{ meaning } f_1 + f_2 \text{ AND } f_1 - f_2$$

With a LO = 13.800 MHz, a mixing product of 455 kHz (0.455) can be generated by a signal of either 14.255 MHz or 13.345 MHz).

$$14.255 \text{ MHz (signal)} - 13.800 \text{ MHz (LO)} = 0.455 \text{ MHz}$$

$$13.800 \text{ MHz (LO)} - 13.345 \text{ MHz (signal)} = 0.455 \text{ MHz}$$

Assuming that the INTENDED signal at 14.255 MHz is an *image response*.

# FM Receivers (see Fig. 5.17)

- Similar to AM/SSB/CW superhets
  - The linear IF amplifier is replaced by a limiter
  - Limiter amplifies the received signal until all amplitude modulated info (noise) is removed and only a square wave of the varying frequency remains
  - Audio information is recovered by a *discriminator* or *quadrature detector* that replaces the product detector

**Fig 5.17:** Once the FM signal is converted to the IF, hi-gain amplifiers called limiters change the signal to a square wave that only varies in frequency (not amplitude). A discriminator converts the frequency variations to audio.

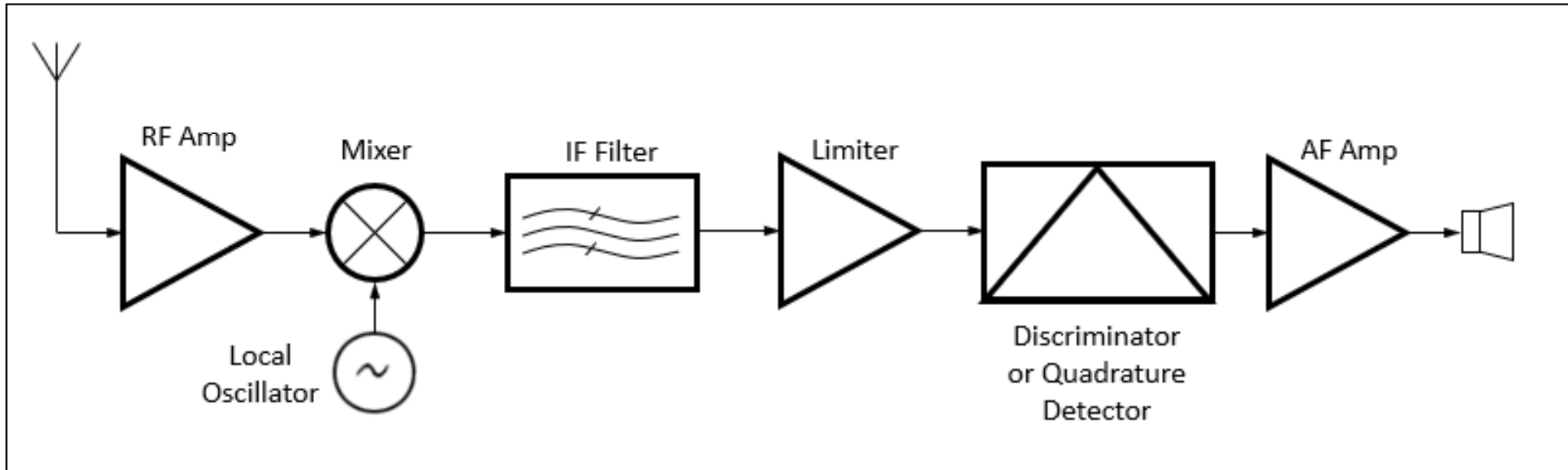

# Digital Signal Processing (DSP)

- The general term for converting signals from analog to digital is *digital signal processing*
- Fig 5.18 (below): DSP systems use an analog-to-digital converter (ADC) to change the signal to digital data. A special type of microprocessor then performs the mathematical operations on the data to accomplish filtering, noise reduction, or other functions. A digital-to-analog converter (DAC) changes the processed data back to analog form for output as audio.

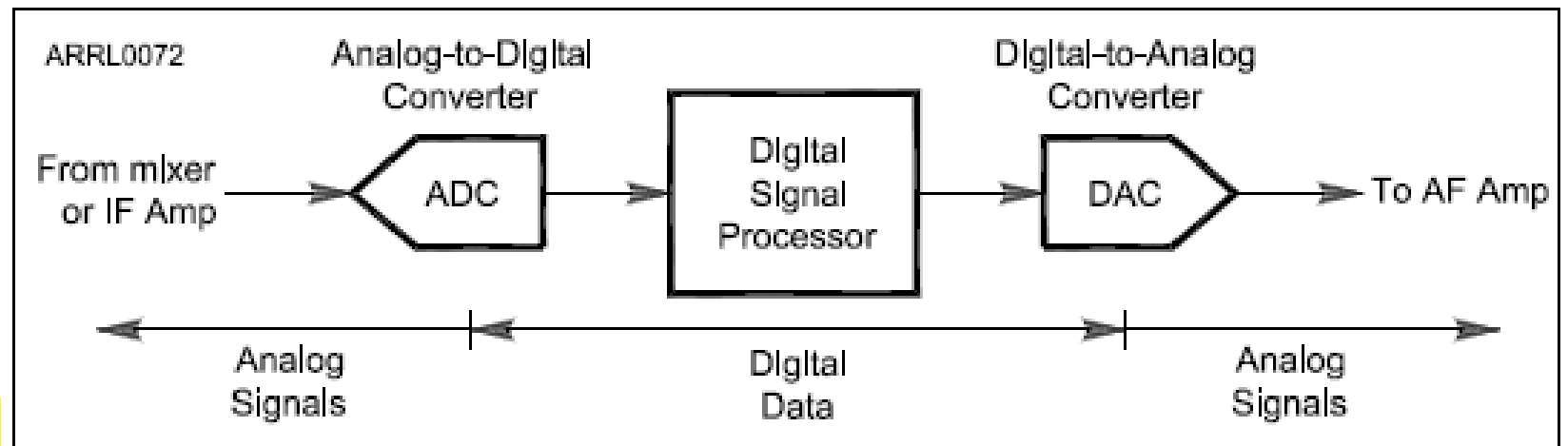

# Digital Signal Processing (cont.)

- Two advantages over analog circuitry
  - Performance & flexibility
- DSP offers selectable preprogrammed filters and allow the operator to adjust the filter bandwidth and shape and even to define new filters
- Expensive functions in analog circuits can be implemented in DSP as a program without additional hardware

# Managing Receiver Gain (RF Gain)

- When looking for weak signals, set RF gain to maximum (for highest receiver sensitivity)
- Lower RF gain volume to reduce background noise
- Automatic gain control (AGC) circuits vary gain of the RF and IF amplifiers so output volume stays constant for both weak and strong signals
  - AGC circuit changes the voltage that controls the IF amp gain. This voltage is read by the *S-meter* (measures *signal* strength).



## RF Gain and AGC (cont.)

- S-meters are calibrated in *S-units*
  - One S-unit equals up to 6 dB (fourfold = 4X) change in signal strength
- S-9 (a strong signal) is located at the midpoint of the display
  - Larger values to the right (20, 40, 60)
  - These correspond to “dB above S-9”
- Reading of “S-9 + 20 dB” is a signal 20 dB (100 times) stronger than an S-9 signal

# Receiver Linearity

- If the received signal is distorted, spurious signals will appear just as if a transmitting station were emitting them
- The most common form of receiver nonlinearity is *overload* (also called *front-end overload*) or *gain compression*
- Solution to overload is to filter out the offending signal or reduce receiver gain (attenuator circuit). Proper use of attenuator and RF gain controls can dramatically reduce received noise distortion caused by strong signals.

# Rejecting Interference and Noise

- *IF* filters narrow the receiver's passband (removes unwanted signals)
- Notch filters remove signals in a very narrow band of frequencies (such as a signal tone from an interfering carrier)
- Passband or *IF* shift adjust receiver's passband above or below the displayed carrier frequency (avoids interference on adjacent frequencies)
- Reverse sideband controls allow switching between receiving CW signals above carrier frequency (USB) and below it (LSB). Avoids interference by placing the signals on the "other side" of the carrier where filtering rejects them.

## Rejecting Interference and Noise (cont.)

- Noise blankers sense short, sharp pulses in the IF signals and reduce the gain of the IF and audio amplifiers during the pulse ... called *blanking*
  - Adjustable noise blankers can be set to blank the receiver at different noise levels
- Noise reduction is performed by the DSP
  - Removes hiss and noise from the audio that is not part of the desired speech, data, or CW
  - Increasing the noise reduction level may cause some of the desired signal to be removed (causes distortion) ... use the least noise reduction require to minimize this

# PRACTICE QUESTIONS

What is the purpose of the notch filter found on many HF transceivers?

- A. To restrict the transmitter voice bandwidth
- B. To reduce interference from carriers in the receiver passband
- C. To eliminate receiver interference from impulse noise sources
- D. To remove interfering splatter generated by signals on adjacent frequencies

What is one advantage of selecting the opposite, or “reverse,” sideband when receiving CW?

- A. Interference from impulse noise will be eliminated
- B. More stations can be accommodated within a given signal passband
- C. It may be possible to reduce or eliminate interference from other signals
- D. Accidental out-of-band operation can be prevented

## How does a noise blanker work?

- A. By temporarily increasing received bandwidth
- B. By redirecting noise pulses into a filter capacitor
- C. By reducing receiver gain during a noise pulse
- D. By clipping noise peaks



What happens as a receiver's noise reduction control level is increased?

- A. Received signals may become distorted
- B. Received frequency may become unstable
- C. CW signals may become severely attenuated
- D. Received frequency may shift several kHz

## What is the purpose of using a receive attenuator?

- A. To prevent receiver overload from strong incoming signals
- B. To reduce the transmitter power when driving a linear amplifier
- C. To reduce power consumption when operating from batteries
- D. To reduce excessive audio level on strong signals

## What does an S meter measure?

- A. Carrier suppression
- B. Impedance
- C. Received signal strength
- D. Transmitter power output

How does a signal that reads 20 dB over S9 compare to one that reads S9 on a receiver, assuming a properly calibrated S meter?

- A. It is 10 times less powerful
- B. It is 20 times less powerful
- C. It is 20 times more powerful
- D. It is 100 times more powerful

How much change in signal strength is typically represented by one S unit?

- A. 6 dB
- B. 12 dB
- C. 15 dB
- D. 18 dB

How much must the power output of a transmitter be raised to change the S meter reading on a distant receiver from S8 to S9?

- A. Approximately 1.5 times
- B. Approximately 2 times
- C. Approximately 4 times
- D. Approximately 8 times

## How is a product detector used?

- A. Used in test gear to detect spurious mixing products
- B. Used in transmitter to perform frequency multiplication
- C. Used in an FM receiver to filter out unwanted sidebands
- D. Used in a single sideband receiver to extract the modulated signal

Which of the following is an advantage of a digital signal processing (DSP) filter compared to an analog filter?

- A. A wide range of filter bandwidths and shapes can be created
- B. Fewer digital components are required
- C. Mixing products are greatly reduced
- D. The DSP filter is much more effective at VHF frequencies



Which parameter affects receiver sensitivity?

- A. Input amplifier gain
- B. Demodulator stage bandwidth
- C. Input amplifier noise figure
- D. All these choices are correct

Which mixer input is varied or tuned to convert signals of different frequencies to an intermediate frequency (IF)?

- A. Image frequency
- B. Local oscillator
- C. RF input
- D. Beat frequency oscillator

What is the term for interference from a signal at twice the IF frequency from the desired signal?

- A. Quadrature response
- B. Image response
- C. Mixer interference
- D. Intermediate interference

Why is it good to match receiver bandwidth to the bandwidth of the operating mode?

- A. It is required by FCC rules
- B. It minimizes power consumption in the receiver
- C. It improves impedance matching of the antenna
- D. It results in the best signal-to-noise ratio

# Section 5.5

## HF Station Installation

- HF operating, with longer wavelengths and higher field strengths, makes grounding and interference control much more important
- The General Exam focuses on three related areas ...
  - Mobile installations
  - RF grounding
  - RF interference

# Mobile Installations – Power Connections

- Mobile radios that can output 100 W require solid power connections capable of supplying 20 A or more
  - Solid state radios perform unpredictably with input voltage drops below the specified minimum power supply voltage
- Best power connection is direct to battery, heavy gauge wire, with both leads fused
  - Do NOT use cigarette lighter or aux socket ... usually rated for only a few amperes ... insufficient to supply a 100 W HF radio\*

*\* If you have an older vehicle ... something from the 1980's, for example ... it may have an old-fashioned cigarette lighter socket rated with enough amps to power your radio. But, confirm with BOTH owner's manuals before you try it.*

**Every machine, operated **WRONGLY** enough, becomes a **SMOKE** machine!**

# Mobile Installations – Antenna Connections

- A limitation of mobile installations is that electrically short (smaller in terms of wavelength) antennas are less efficient than full-sized ones
  - Particularly true on lower frequency bands
- Tips to improve antenna performance
  - Use most efficient antenna you can
  - Make sure your ground connections to vehicle are solid
  - Mount antenna where it is clear of metal surfaces

# Mobile Interference

- Different interference sources than home stations
  - Ignition noise (spark plugs firing) ... n/a in diesel engines
  - Alternator whine
  - Vehicle's accessories
  - On-board control computers
  - Electric motors in fuel pumps, windows, and battery charging systems
  - Winch motors in 4X4 vehicles & trucks



# Grounding & Bonding

- AC grounding prevents hazardous voltages from appearing on equipment chassis, creating a shock hazard
- To manage RF, bond equipment enclosures together (see Fig 5.19) ... *Bonding* means to connect two points together to minimize voltage differences between them
- During digital operation, unwanted RF currents can cause distortion, erratic operation of computer interfaces, activate transmitter improperly, and garble digital protocols

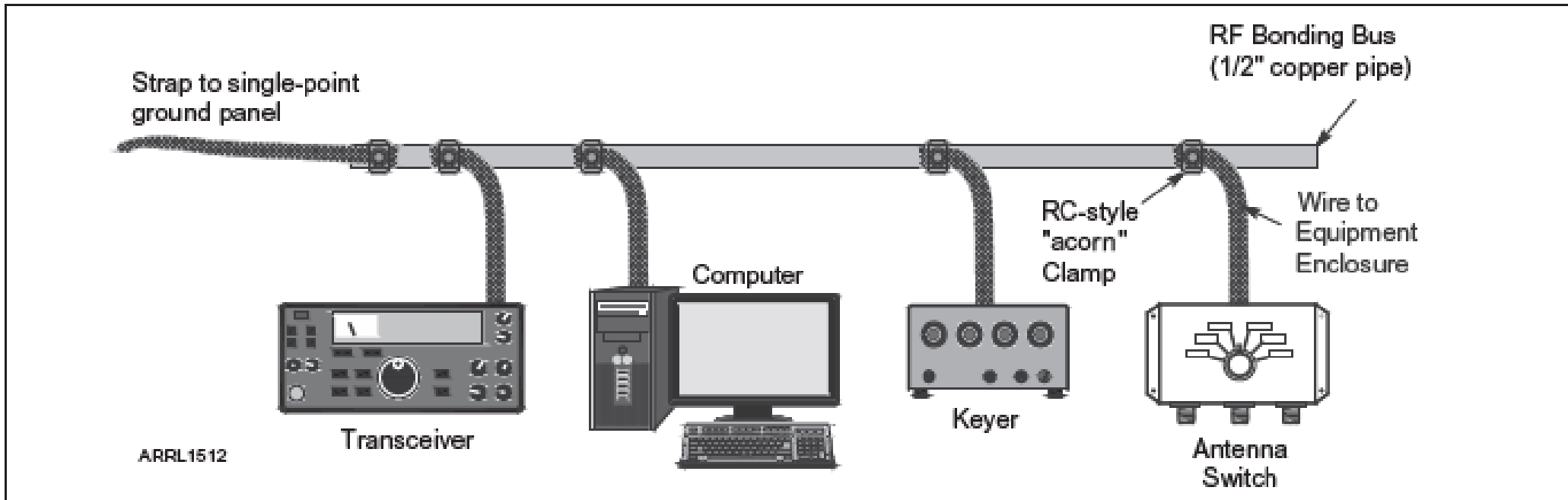

Figure 5.19 — This example of a typical RF bonding bus at the operating position helps keep all of the equipment at the same RF voltage.

# Grounding & Bonding (cont.)

- Bonding basics ...
  - Connect all metal equipment enclosures directly together or to a common RF bonding bus
  - Keep connections, straps, and wires SHORT
  - Use short, heavy conductors (#12 or #14 AWG) or strap
  - If strong RF is present, use a piece of wide flashing or screen under the equipment, connected to the bonding bus
- If ground connection is resonant at an odd number of  $\frac{1}{4}$  wavelengths, it will generate high impedance (enables RF voltages on enclosures and cables)

# Grounding & Bonding (cont.)

- *Ground loops* are created by a continuous current path around a series of equipment connections
- Loop acts as a single-turn inductor ... picks up voltages from magnetic fields (from transformers, ac wiring, etc.)
- Result is a “hum” in transmitted signals or that interferes with control or data signals
- Ground loops can be avoided by connecting all ground conductors to the RF bonding bus

# RF Interference (RFI): Causes & Solutions

RFI	CAUSE	SOLUTION
Fundamental Overload	Radio/TV receivers unable to reject strong signals ... causes distortion or inability to receive desired signal	Prevent signal by using filters in signal path
Common-mode & Direct pickup	From electronic equipment with internal electronics ... picked up on outside of cable shields and conductors of unshielded connections	Block current with RF chokes
Harmonics	Spurious emissions from an amateur station may be received by radio or TV equipment (there is no 1 <sup>st</sup> harmonic ... it's called the <i>fundamental frequency</i> )	Use a low-pass filter at the transmitter
Intermodulation	Poor contacts between conductors picking up RF signals can create a nonlinear connection that acts as a mixer and mixing products from the signals	Find/repair the poor contact or block the RF signals (look for odd-order harmonics ... closest to the original frequencies)
Arcing	A spark or sustained arc creates radio crackling or buzz over wide frequency range, (from power-line hardware)	May require power company to make repairs; filter specific equip.

# Common RFI Symptoms

- RFI is quite varied
- Some more common types are ...
  - CW, FM, or data: Interference consists of ON/OFF buzzes, humming, clicks or thumps when the interfering signal is transmitted
  - AM phone: Equipment experiencing overload or direct detection will often emit a replica of the speaker's voice
  - SSB voice: Similar to AM phone, but voice will be distorted or garbled

# Suppressing RFI

- Filters are effective and easy to install
- Block RF by placing an impedance in its path
  - Form conductor carrying RF current into an RF choke by winding it around or through a ferrite core
- Ferrite beads placed on cables to prevent RF common-mode from flowing on outside of cables/shields
- Interference to audio equipment and sensor connections can be eliminated by using a small (100 pF to 1 nF) bypass capacitor across balanced connections

# PRACTICE QUESTIONS



Which of the following might be useful in reducing RF interference to audio frequency devices?

- A. Bypass inductor
- B. Bypass capacitor
- C. Forward-biased diode
- D. Reverse-biased diode

Which of the following could be a cause of interference covering a wide range of frequencies?

- A. Not using a balun or line isolator to feed balanced antennas
- B. Lack of rectification of the transmitter's signal in power conductors
- C. Arcing at a poor electrical connection
- D. Using a balun to feed an unbalanced antenna

What sound is heard from an audio device experiencing RF interference from a single sideband phone transmitter?

- A. A steady hum whenever the transmitter is on the air
- B. On-and-off humming or clicking
- C. Distorted speech
- D. Clearly audible speech

What sound is heard from an audio device experiencing RF interference from a CW transmitter?

- A. On-and-off humming or clicking
- B. A CW signal at a nearly pure audio frequency
- C. A chirpy CW signal
- D. Severely distorted audio

What is a possible cause of high voltages that produce RF burns?

- A. Flat braid rather than round wire has been used for the ground wire
- B. Insulated wire has been used for the ground wire
- C. The ground rod is resonant
- D. The ground wire has high impedance on that frequency

What is a possible effect of a resonant ground connection?

- A. Overheating of ground straps
- B. Corrosion of the ground rod
- C. High RF voltages on the enclosures of station equipment
- D. A ground loop

Which of the following would reduce RF interference caused by common-mode current on an audio cable?

- A. Place a ferrite choke on the cable
- B. Connect the center conductor to the shield of all cables to short circuit the RFI signal
- C. Ground the center conductor of the audio cable causing the interference
- D. Add an additional insulating jacket to the cable

## How can the effects of ground loops be minimized?

- A. Connect all ground conductors in series
- B. Connect the AC neutral conductor to the ground wire
- C. Avoid using lock washers and star washers when making ground connections
- D. Bond equipment enclosures together



What could be a symptom caused by a ground loop in your station's audio connections?

- A. You receive reports of “hum” on your station's transmitted signal
- B. The SWR reading for one or more antennas is suddenly very high
- C. An item of station equipment starts to draw excessive amounts of current
- D. You receive reports of harmonic interference from your station

What technique helps to minimize RF “hot spots” in an amateur station?

- A. Building all equipment in a metal enclosure
- B. Using surge suppressor power outlets
- C. Bonding all equipment enclosures together
- D. Placing low-pass filters on all feed lines

## Why must all metal enclosures of station equipment be grounded?

- A. It prevents a blown fuse in the event of an internal short circuit
- B. It prevents signal overload
- C. It ensures that the neutral wire is grounded
- D. It ensures that hazardous voltages cannot appear on the chassis

Which of the following direct, fused power connections would be the best for a 100 watt HF mobile installation?

- A. To the battery using heavy-gauge wire
- B. To the alternator or generator using heavy-gauge wire
- C. To the battery using insulated heavy duty balanced transmission line
- D. To the alternator or generator using insulated heavy duty balanced transmission line

Why should DC power for a 100-watt HF transceiver not be supplied by a vehicle's auxiliary power socket?

- A. The socket is not wired with an RF-shielded power cable
- B. The socket's wiring may be inadequate for the current drawn by the transceiver
- C. The DC polarity of the socket is reversed from the polarity of modern HF transceivers
- D. Drawing more than 50 watts from this socket could cause the engine to overheat

Which of the following most limits an HF mobile installation?

- A. “Picket fencing”
- B. The wire gauge of the DC power line to the transceiver
- C. Efficiency of the electrically short antenna
- D. FCC rules limiting mobile output power on the 75-meter band

Which of the following may cause receive interference in a radio installed in a vehicle?

- A. The battery charging system
- B. The fuel delivery system
- C. The control computers
- D. All these choices are correct

How does a ferrite bead or core reduce common-mode RF current on the shield of a coaxial cable?

- A. By creating an impedance in the current's path
- B. It converts common-mode current to differential mode
- C. By creating an out-of-phase current to cancel the common-mode current
- D. Ferrites expel magnetic fields



Which intermodulation products are closest to the original signal frequencies?

- A. Second harmonics
- B. Even-order
- C. Odd-order
- D. Intercept point

What process combines two signals in a non-linear circuit or connection to produce unwanted spurious outputs?

- A. Intermodulation
- B. Heterodyning
- C. Detection
- D. Rolloff

Which of the following is an odd-order intermodulation product of frequencies F1 and F2?

- A.  $5F1 - 3F2$
- B.  $3F1 - F2$
- C.  $2F1 - F2$
- D. All these choices are correct

**HOW TO CALCULATE:** To obtain the answer, remember that intermodulation refers to mixing products ( $f_1 \pm f_2$ ). The *odd-order* intermodulation refers to a *harmonic* (i.e., a spurious harmonic emission). Since odd-order harmonics are closest to the original (fundamental) frequency, we have to assume they're referring to the second harmonic of F1 (instead of the 3<sup>rd</sup>, 4<sup>th</sup>, etc.). The frequency of this 2<sup>nd</sup> harmonic is represented by the formula ( $2 \times f_1$  or  $2F1$ ). So, the two intermodulation products of F1 and F2, where F1 is really the 2<sup>nd</sup> harmonic of F1 would be  $2F1 + F2$  and  $2F1 - F2$ . The second intermodulation product ( $2F1 - F2$ ) matches answer **C**.

END OF CHAPTER 5 PART 2 OF 2

Slides created by ...

Jerry D. Kilpatrick

KØILP (Amateur Radio)

PGØØØ72373 (Commercial Operator)

[KØILP.NC@gmail.com](mailto:KØILP.NC@gmail.com)

Feel free to contact me if you find errors or have suggestions for improvement.